

Vakuum-Lösungen

Applikations-
Unterstützung

Service

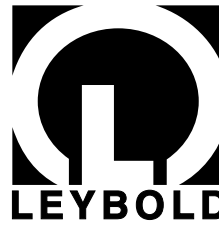

LEYBOLD VACUUM

GA 05.208/11

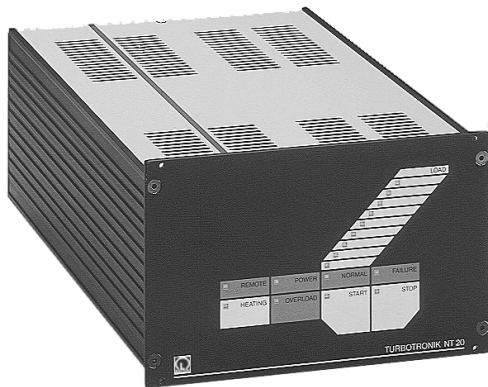

TURBOTRONIK NT 20

Elektronischer
Frequenzwandler

Electronic Frequency
Converter

Kat.-Nr. / Cat. No.

857 20/21/22

Gebrauchsanleitung

Operating Instructions

Contents

	Page
1 Description	16
1.1 Design and Function	16
1.2 Standard Specification	18
1.3 Technical Data	18
1.4 Ordering Data	19
2 Connection	20
2.1 Setting the Mains Voltage	20
2.2 Connecting the TURBOVAC	20
2.3 Connecting the Forevacuum Pump	20
2.4 Connecting the Cooling	20
2.5 Connecting the Venting Valve	21
2.6 Connecting the Flange Heater	21
2.7 Connecting the Remote Control	23
2.10 Installing the TURBOTRONIK	24
3 Operation	25
3.1 Start-up	25
3.2 Start-up of the TURBOVAC	25
3.3 Bakeout of the TURBOVAC	26
3.4 Operation	26
3.5 Shut-down of the TURBOVAC	26
3.6 Venting of the TURBOVAC	26
3.7 Shut-down of the TURBOTRONIK	26
3.8 Maintenance	26
4 Troubleshooting	27
EC Conformance Declaration	15

Die deutsche Gebrauchsanleitung beginnt auf Seite 2

The TURBOTRONIK NT 20 has been manufactured to the engineering standards and approved safety regulations. Even so when not properly installed or when not used and operated as intended the frequency converter may be a source of danger and can cause damage.

Warning

Indicates procedures that must be strictly observed to prevent hazards to persons.

Caution

Indicates procedures that must be strictly observed to prevent damage to, or destruction of the appliance.

Figures

The references to diagrams, e. g. (2/10), consist of the Fig. No. and the Item No. in that order.

We reserve the right to alter the design or any data given in these Operating Instructions. The illustrations are not binding.

1 Description

1.1 Design and Function

The electronic frequency converter TURBOTRONIK NT 20 is used to drive the following turbo molecular pumps:

- TURBOVAC 150, 360,
- TURBOVAC 150 CSV, 360 CSV,
- TURBOVAC 150 V, 360 V,
- TURBOVAC 151, 151 C, 361, 361 C,
- TURBOVAC 600, 600 C,
- TURBOVAC 1000, 1000 C, 1100 C.

These pumps each comprise a three-phase asynchronous motor with the appropriate rating to drive the rotor.

The TURBOTRONIK NT 20 converts the single-phase mains voltage into a three-phase AC voltage with regulated frequency and amplitude.

Each installed TURBOVAC has been individually coded. The respective pump code must be entered using the DIP switches provided. For safety reasons, the TURBOVAC will not start up unless the two codes match.

The acceleration sequence, the regulation during operation, and the output speed will vary depending on the installed pump model.

The TURBOTRONIK NT 20 does not support the pump models TURBOVAC 150 H and TURBOVAC 360 H.

LEYBOLD customer service can adjust the speed of each TURBOVAC to $\pm 5\%$, if required.

External control and monitoring equipment, e.g. the LEYBOTRONIK I can be connected via floating terminal strip located at the rear of the TURBOTRONIK. Both the remote control unit and the lines for the pump system's status signals are connected here. These terminals also provide connections for controlling the forepump, the heater or valves.

An RS-232 interface provides further monitoring options. All the main internal parameters are output cyclically every 8 seconds. More details on request.

The front panel of the TURBOTRONIK NT 20 features the following three control keys:

HEATING, START and STOP.

Essential operating conditions such as speed, load or failure are indicated via LEDs.

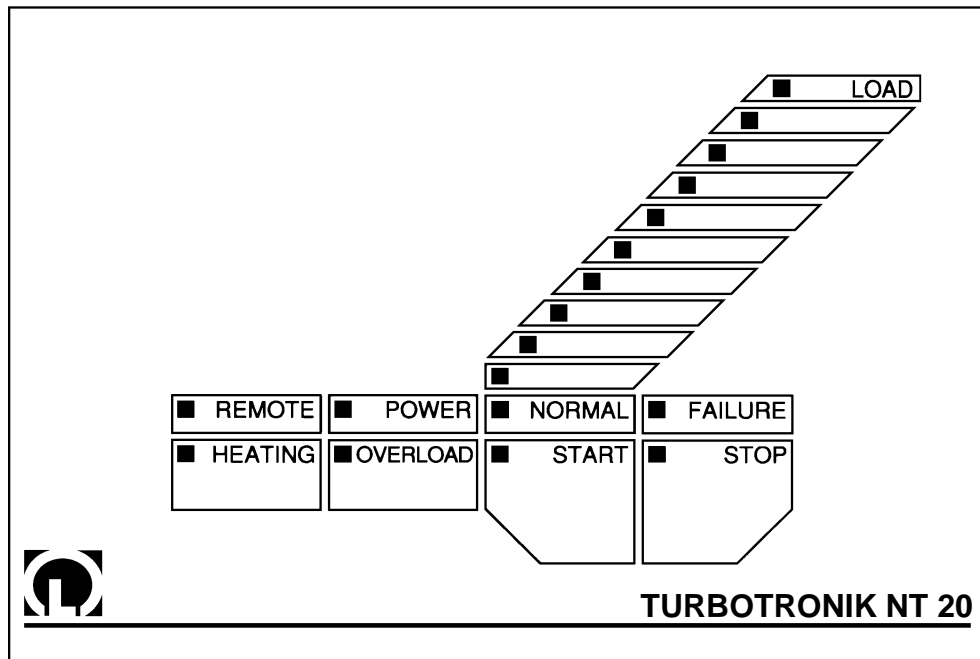

Fig. 1 Front panel of the TURBOTRONIK NT 20, explanation see table 1 and 2

Table 1: Operational Status Display of the Front Panel LEDs

LED	Color	Display
LOAD	green	LED "START" lights up: speed of the TURBOVAC (individual LED, linear display) LED "OVERLOAD" lights up: speed of the TURBOVAC (individual LED, linear display) LED "NORMAL" lights up: motor current (LED chain, logarithmic display) LED "FAILURE" lights up: failure code (LED "LOAD" flashes)
REMOTE	yellow	Lights up when the converter is controlled via the remote control inputs; key manipulation is ignored.
POWER	green	Lights when mains power supply is on.
NORMAL	green	Lights during normal operation, speed is above 80 % of the target speed. Flashes in case of acceleration and "OVERLOAD".
FAILURE	red	Lights in case of failure.
HEATING	green	Lights when heating is on. Flashes when heating has been preselected.
OVERLOAD	yellow	Lights in case of overload, i. e. speed is below 80 % of the target speed having finished the acceleration sequence.
START	green	Lights in case of TURBOVAC's acceleration. Flashes when the delay start-up time is active.
STOP	green	Lights when the TURBOVAC is shut down.

Table 2: Functions of the Front Panel Keys

Key	Functions
HEATING	Switching the TURBOVAC's heating on and off.
START	Starting the TURBOVAC's acceleration.
STOP	Braking the TURBOVAC. Resetting a failure report.

1.2 Standard Specifications

TURBOTRONIK NT 20 table-top electronic frequency converter with housing.

Power linecord

- with shock-proof plug (Cat. No. 857 20)
- or with US mains plug (Cat. No. 857 21/22),

Miniature fuses: 2 T 6.3 A; 2 T 4.0 A; 2 T 3.15 A; 2 T 1.0 A; 2 T 0.2 A

as well as three mains plugs,

two terminal strips,

one portable socket-outlet and

the Operating Instructions.

1.3 Technical Data

Mains voltage, with selector switch	100/120/220/240 V,+10%/-15%
Mains frequency	50/60 Hz
Power consumption including all connected units	<1000 VA
Power consumption of the TURBOVAC	<400 VA
Power output (motor)	
Nominal voltage	42 V
Link circuit current limitation	
Acceleration (max. 10 min.)	5 A
Continuous operation	3.5 A

TURBOVAC speed ratings

TURBOVAC 150 / 151	50 000 min ⁻¹
TURBOVAC 360 / 361	45 000 min ⁻¹
TURBOVAC 600	36 000 min ⁻¹
TURBOVAC 1000	36 000 min ⁻¹
TURBOVAC 1100	30 000 min ⁻¹

Control Inputs - digital, floating

each terminal	25 V _{eff} AC max., 60 V DC
	versus protective conductor
	LEYBOTRONIK I compatible
High level; between "+" and "-" terminal	13 V...33 V/max. 10 mA
Low level; between "+" and "-" terminal	0 V...7 V
Pulse duration	>200 ms
for remote control active "START" pump, "STOP" pump, heater On/Off	

Control Outputs

Relay	max. 250 V AC, 3 A
	50 V DC, 2 A (resistive load)
for normal operation	operating contact
for acceleration	operating contact
for failure	changeover contact
FOREPUMP Relay point	max. 6 A, 750 VA, 250 V

Supply Outlets VALVE; HEATER, FAN

A relay is used to switch through the mains voltage.

The permissible current for all 3 outlets together is

4.5 A at 100 - 120 V AC
6 A at 220 - 240 V AC

Interface for data output	RS 232/V.24
Connector	25-pin, D-shell, female
Baud rate	9,600

Operating temperature; with sufficient free convection for side profiles	0-45°C (32°F - 113°F)
Storage temperature	-25°C...+70°C (-77°F - +158°F)
Humidity class	F, DIN 40 040
Protection class	1
Electrical safety to	IEC 1010/VDE 0411
Interference radiation to VDE 0871	Level B
EMC to IEC 801-2	Severity 2

Dimensions	1/2 19", 3HU*
Weight	8.5 kg

* Height units - modular spacings high

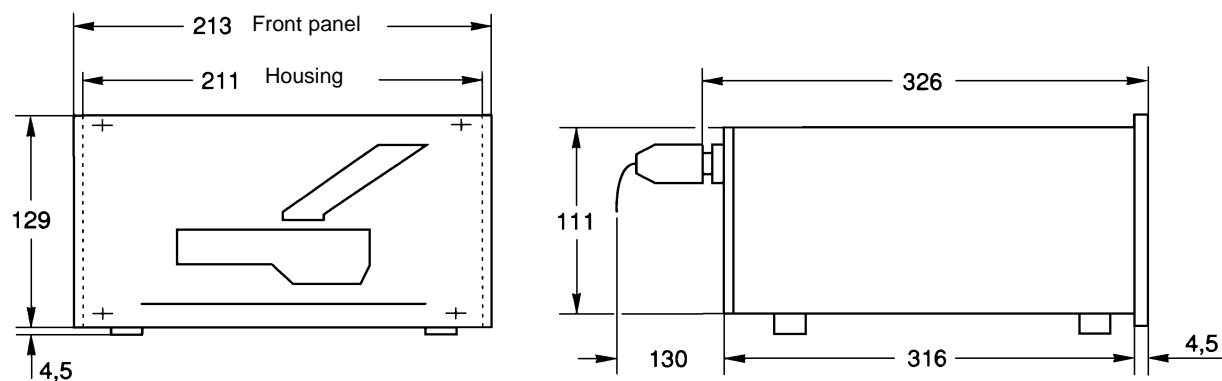

Fig. 2 Dimensional drawing, dimensions in mm

1.4 Ordering Data

	Cat. No.
Electronic frequency converter TURBOTRONIK NT 20	
230 V	857 20
120 V	857 21
100 V	857 22
Connection line to the TURBOVAC	
3 m long	857 65
5 m long	857 66
10 m long	857 67
20 m long	857 68
Mounting frame 19", 3HU;	161 00
Pump system control LEYBOTRONIK I	013 10
Power unit for LEYBOTRONIK I	upon request
Power failure airing valve	174 26
Delaying venting device	012 44
Venting valve for delaying venting device	012 45

2 Connection

Warning



Connections for forevacuum pump, cooling, venting valve and flange heater must be done by a qualified electrician in accordance with the applicable safety regulations.

Warning



There are hazardous voltages present inside the TURBOTRONIK. Open the TURBOTRONIK only after it has been isolated from the mains power supply.

2.1 Setting the Mains Voltage (optional)

The mains voltage setting of the TURBOTRONIK NT 20 can be changed; see „Technical Data“.

Caution

The TURBOTRONIK will be damaged if the voltage selector switch is set incorrectly when connected to the mains.

To change this setting, remove the dummy plug (3/13) with a screwdriver and reinsert it according to the stamped-on voltage setting. The selected voltage indication must be in the immediate proximity of the arrow.

If you do change the voltage setting, please also change the line power fuse accordingly; see the table.

Fuses (*) slow-blow)

	LINE	VALVE	HEATING	FAN
100/120 V	T ^{*)} 6.3 A	T 0.2 A	T 3.15 A	T 1.0 A
220/240 V	T 4.0 A	T 0.2 A	T 3.15 A	T 1.0 A

In case of need, other fuses may be installed for “VALVE”, “HEATING” and “FAN”. However, the sum of the fuses’ capacity for the three connections must not exceed:

- 4.5 A for 100/120 V
- 6.0 A for 220/240 V.

Plug the power linecord into the socket (3/12).

2.2 Connecting the TURBOVAC

Insert and fasten the connection line to the motor of the TURBOVAC at (3/3) and to the TURBOVAC itself.

2.3 Connecting the Forevacuum Pump

Connect the forepump to the relay contact output (3/2). When pressing the START key the contact is closed without any delay and the forepump is switched on.

The forevacuum pump is shut down when the STOP key has been pressed and when a failure has occurred. Switching examples are given in fig. 4.

A starting delay for the TURBOVAC can be set at (3/6); see Section 3.1

2.4 Connecting the Cooling

The mains power supply to the socket (3/8) is switched on as soon as the TURBOVAC acceleration sequence begins; max. load 100 VA. The relevant fuse (3/10) is below the socket.

The power supply is switched off when the STOP key is pressed or when the POWER switch is turned to off or when the power cord is disconnected from the mains power supply.

A solenoid valve for the water cooling or a fan can be connected to the socket (3/8).

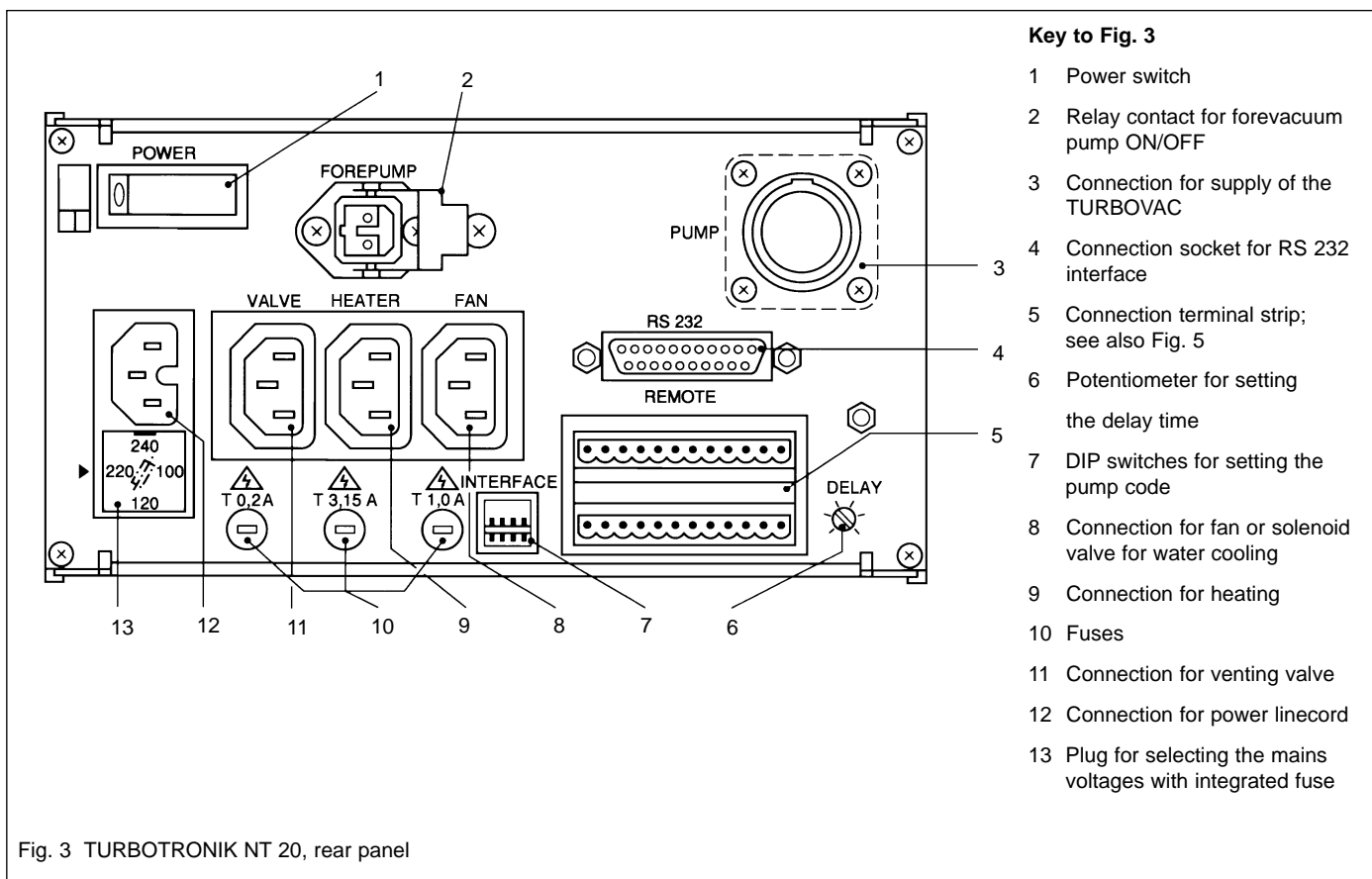

- Key to Fig. 3**
- 1 Power switch
 - 2 Relay contact for forevacuum pump ON/OFF
 - 3 Connection for supply of the TURBOVAC
 - 4 Connection socket for RS 232 interface
 - 5 Connection terminal strip; see also Fig. 5
 - 6 Potentiometer for setting the delay time
 - 7 DIP switches for setting the pump code
 - 8 Connection for fan or solenoid valve for water cooling
 - 9 Connection for heating
 - 10 Fuses
 - 11 Connection for venting valve
 - 12 Connection for power linecord
 - 13 Plug for selecting the mains voltages with integrated fuse

Fig. 3 TURBOTRONIK NT 20, rear panel

2.5 Connecting the Venting Valve

The mains power supply to the socket (3/11) is switched on without any delay when START is activated. The power is turned off when STOP or FAILURE are activated; max. load 100 VA. The relevant fuse (3/10) is below the socket.

Power Failure Airing Valve or Purge Gas- and Venting Valve

If the TURBOVAC is operated **without** purge gas connect up the power failure airing valve to the VALVE socket (3/11).

If the TURBOVAC is operated **with** purge gas connect up the purge gas- and venting valve to the VALVE socket (3/11).

A short power failure will immediately initiate venting of the pump.

Delayed Venting Device and Venting Valve

When shutting down or in case of a power failure the connection of the delayed venting device (see Section 1.4) allows for setting the start and duration of the ven-

ting sequence in order to protect a system or a process-procedure.

The presetting time can vary between 3 to 15 minutes.

A short power failure does not entail an unwanted venting.

Connect the delayed venting device to (3/11).

2.6 Connecting the Flange Heater

(Only for pumps with CF connection flange)

The mains power supply to the socket (3/9) is switched on when HEATING is activated, provided that the pump operation status is NORMAL; max. load 300 VA.

The relevant fuse (3/10) is below the socket.

Connect the flange heater to the TURBOVAC at socket (3/9) HEATER.

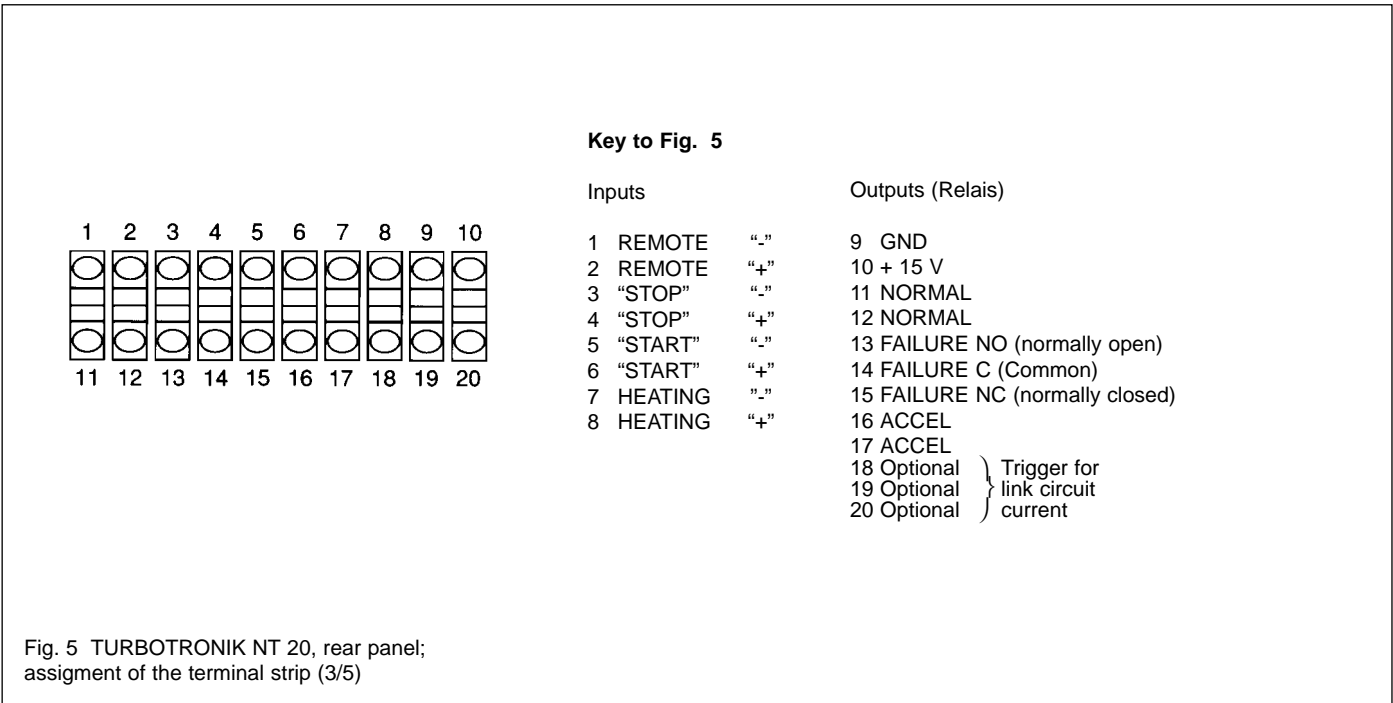
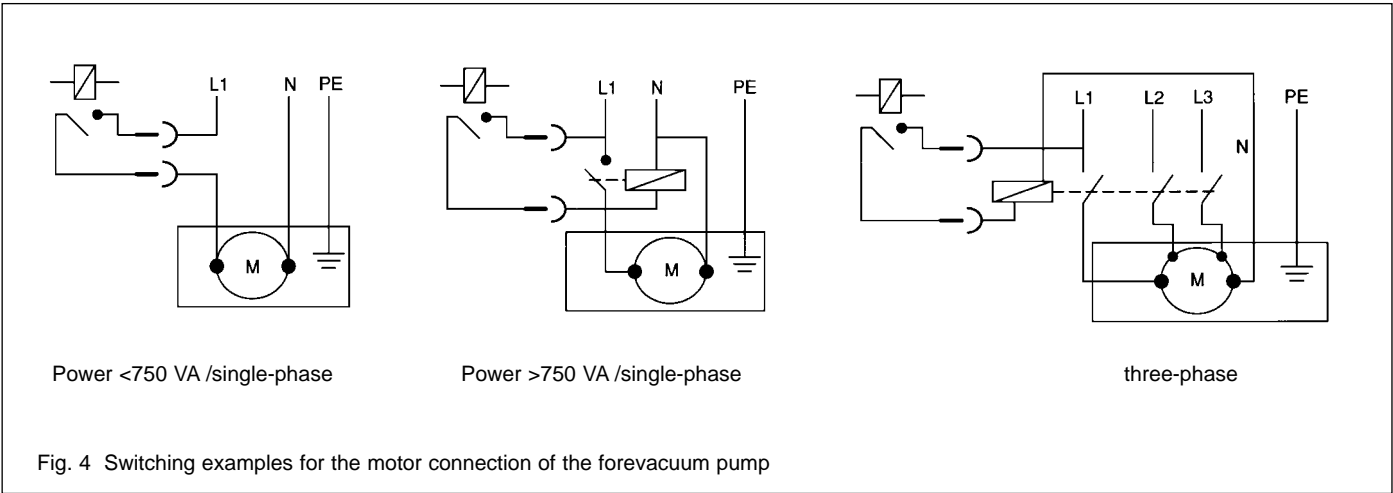
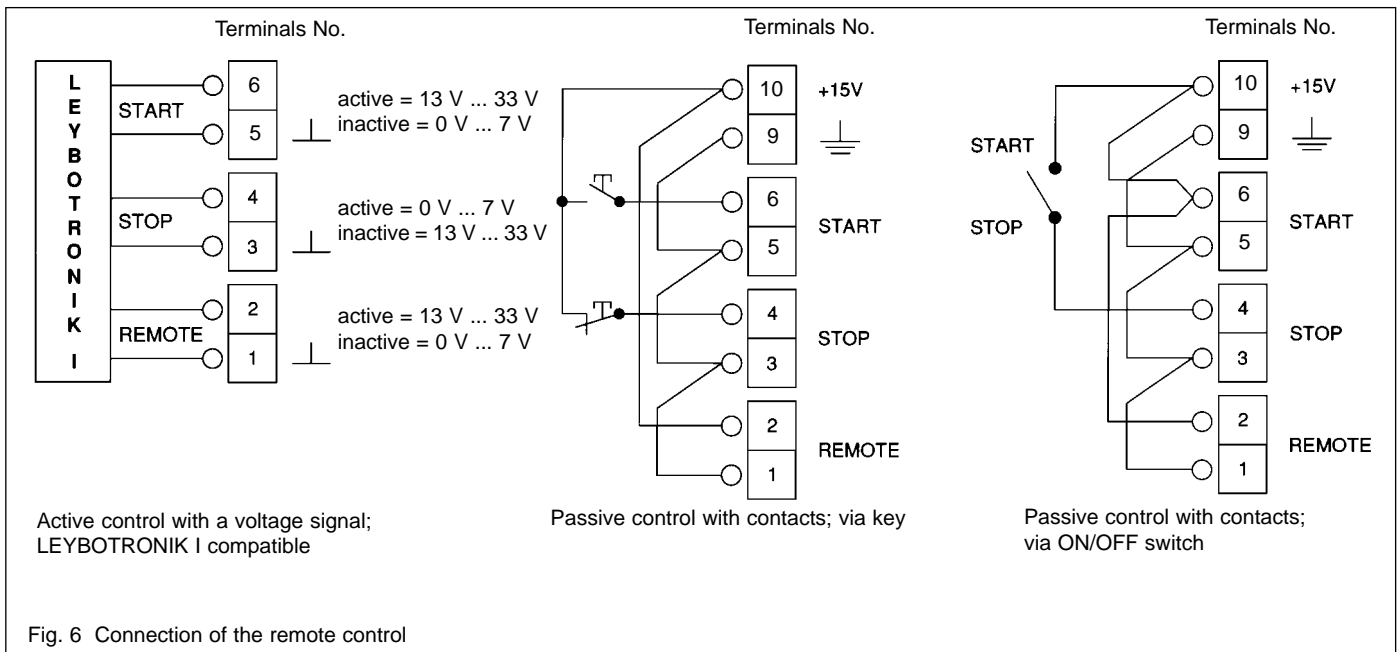

Table 3

Relay status	VALVE (3/11)	HEATER (3/9)	FAN (3/8)	FOREPUMP (3/2)	ACCEL Fig. 5	FAILURE 13/14 Fig. 5	FAILURE 14/15 Fig. 5	NORMAL
Power off	open	open	open	open	open	open	closed	open
STOP	open	open	open	open	open	open	closed	open
Delayed start-up device	Mains power applied	open	open	closed	closed	open	closed	open
Acceleration	Mains power applied	open	Mains power applied	closed	closed	open	closed	open
NORMAL	Mains power applied	Mains power applied*	Mains power applied	closed	open	open	closed	closed
Overload	Mains power applied	Mains power applied*	Mains power applied	closed	open	open	closed	closed
Failure; TURBOVAC rotates	open	open	open	open	open	closed	open	open

* if selected



2.7 Connecting the Remote Control Unit

For the signal assignments of the terminal strip (3/5) refer to fig. 5.

Switching examples see fig. 6.

Technical Data see section 1.3.

Relay statuses see table 3.

Remote control is by external PLC signals or via the unit's own outlets 9 (GND) and 10 (+15V).

If pulsed signals are used, the pulse duration must be greater than 200 ms.

Note for Switching Example "ON/OFF" Switch

See fig. 6. If instead of the "ON-OFF switch" a jumper is established between Pin 4 and 10, the TURBOVAC will start up automatically once the TURBOTRONIK is switched on.

Inputs - Remote control active

"REMOTE"	Disables the keys and activates the remote control inputs (continuous signal; High-active)
"START" pump	Impulse or continuous signal; High-active
"STOP" pump	Impulse or continuous signal; Low-active
"HEATING"	Heating ON/OFF steady-state signal; High = On, Low = Off

Due to safety reasons the "STOP" function (Low-active) is dominant.

In order to start the TURBOTRONIK via the remote control:

the "REMOTE"-inputs must be activated i.e. high-level between "+" and "-" terminal,

the "STOP"-inputs must be inactivated i.e. high-level between "+" and "-" terminal,

the "START"-inputs must be activated i.e. high-level between "+" and "-" terminal.

Outputs

Acceleration	(working contact)
Normal operation	(working contact)
Failure	(changeover contact)

The +15 V voltage supply can be used to activate the REMOTE inputs.

2.8 Installing the TURBOTRONIK

For installation in a rack use the mounting frame 19", 3 HU!

The heat dissipation of the TURBOTRONIK must not be obstructed. Insure a sufficient ventilation - the ambient temperature during operation must not exceed 45°C (113°F). Make sure that there is sufficient heat dissipation for the two side profiles. As a general rule, it is **not** possible to install two TURBOTRONIK NT 20 units in one 19" rack.

If - after installation - the rear of the TURBOTRONIK is no longer accessible, switch on the power switch (3/1) and the DIP switches before mounting and if nec. set the starting delay; refer to section 3.1.

Warning



If the TURBOVAC is built into a rack the mains plug is not within easy reach. Therefore install a separation between the TURBOTRONIK and the mains when you build it into a rack.

Warning



Do not operate the TURBOTRONIK with the standard mains lead in chemically aggressive surroundings. If you operate the TURBOTRONIK in chemically aggressive surroundings replace the mains lead by a resistant one.

3 Operation

3.1 Start-up

DIP switch settings

The DIP switches located at the rear of the unit - "INTERFACE" - (3/7) must be set to match the respective pump model; see Table 4.

In addition to the automatic pump identification function, the pump-specific DIP switch settings also act as a safety feature. This insures that the pump in question is protected from mechanical destruction even in the event of defects in the line cord.

Caution

Do not connect the unit to any TURBOVAC turbo-molecular pump model that is not listed in these operating instructions.

Insert the power plug.

Switch on the power switch (3/1).

When the power switch is turned on, all LEDs light up for approx. 2 s as a function check.

The green LED POWER remains on.

Following this, a self-test is run:

1. check that the line cord is connected,
2. identification of the TURBOVAC model.

Setting the Start-up Delay

You can set a "START"-up delay of up to five minutes at the rear of the unit at (3/8).

Due to the starting delay the TURBOVAC starts after the forevacuum pump.

3.2 Start-up of the TURBOVAC

Pressing the START key initiates the acceleration sequence; if a forevacuum pump is connected it will start up immediately.

If a delay has been set, the START LED will flash during the delay period, after which it will remain on continuously and the TURBOVAC starts. The acceleration relay is already active during the delay period.

The NORMAL LED **flashes** during acceleration. The LED chain indicates the increasing speed with one LED each. When 80% of the target speed has been reached, the LED NORMAL remains on continuously, the START LED extinguishes.

During normal operation the LED chain indicates the course of the increasing motor power consumption; the increasing current (load) drawn by the TURBOVAC is indicated by the LED chain with one LED each lighting up after the other starting at the bottom and moving upwards.

Table 4: DIP switch settings

TURBOVAC	Cat. No.	DIP switch			
		1	2	3	4
150, 150 CSV	854 69/70/71/79/80/81, 855 02/03/04/05, 894 10, 895 44	OFF	ON	ON	ON
150 V	856 10/11/12, 894 11	ON	ON	ON	OFF
151	856 30/31/32/35, 894 13	ON	OFF	ON	OFF
360, 360 CSV	854 50/51/56/57/60/61, 855 07/08/09/15, 894 20, 896 67	ON	OFF	ON	ON
360 V	856 20/21/22/23, 894 21	ON	ON	OFF	ON
361	856 70/71/72/73/75/77, 894 23	OFF	OFF	ON	ON
600	856 80/81/82, 894 24/25	OFF	ON	ON	OFF
1000	854 90/91/96/97, 855 35/36/38/39, 894 89/99, 895 89	OFF	OFF	OFF	OFF
1100	894 80*	ON	OFF	OFF	ON

* only for NT 20, Cat. No. 857 20 from serial no. Z96 01221 and for NT 20, Cat. No. 857 21 from serial no. Z96 00321

The following DIP switch settings are not permissible:
 ON ON ON ON,
 OFF ON OFF ON,
 ON ON OFF OFF

3.3 Bake-out of the TURBOVAC

Bake-out is only necessary when the pump is to attain especially low pressures. Water cooling is required for the bake-out sequence.

Pressing the HEATING key switches the flange heater ON and OFF. The green LED in the key lights up when the heating is ON.

With preselection the LED flashes during the acceleration phase; during NORMAL and activated heating the LED lights continuously.

3.4 Operation

During NORMAL operation, the LED NORMAL lights and the LED chain shows - starting at the bottom and moving upwards - the current consumed.

If the target speed of the TURBOVAC cannot be maintained during normal operation due to overloading (pressure, excessive TURBOVAC or TURBOTRONIK temperature), the TURBOTRONIK will switch to the OVERLOAD mode.

In this mode, the LED OVERLOAD lights up and the LED NORMAL flashes.

The LED chain shows the corresponding speed.

The OVERLOAD mode is not a failure, but can result in a shut down depending on the cause of overload, e.g. if the temperature continues to rise.

3.5 Shut-down of the TURBOVAC

Pressing the STOP key switches off the pump drive.

The forevacuum pump will be switched off provided it is connected via (3/2); the heating will be switched off provided it is connected via (3/9); the TURBOVAC will be vented if the venting valve is connected via (3/11).

The LED in the STOP key lights up, the LED NORMAL goes off. The TURBOVAC runs down until it stands still.

If a malfunction "FAILURE" occurs the malfunction signal can be reset via the STOP key provided the cause of malfunction has been eliminated.

3.6 Venting of the TURBOVAC

Vent the TURBOVAC every time the TURBOVAC is switched off in order to prevent a potential backstreaming of oil vapors from the forevacuum line to the high-vacuum side.

If a power failure airing valve or a delayed venting device is connected to the socket (3/11) VALVE the TURBOTRONIK controls venting automatically.

3.7 Shutdown of the TURBOTRONIK

Press the STOP key.

The LEDs in the keys START, STOP and NORMAL are extinguished.

Switch the power switch (3/1) to the "0" position.

3.8 Maintenance

The converter essentially requires no servicing since it contains no components which could be adjusted.

Depending on the installation particulars and the ambient conditions, the converter may collect grime (dust, moisture) on the inside. Such contamination can lead to malfunctions, overheating or short circuits and will have to be avoided to the maximum extent possible. The LEYBOLD Service Department can clean the converter. We recommend adhering to a cleaning interval of about three years.

Warning



Only qualified personnel or the Leybold Service Department may carry out work on the converter.

Potentially fatal voltages are present inside the converter.

The unit shall be disconnected from the power supply before commencing any work where the converter housing will be opened.

The converter contains components which could be damaged by electrostatic discharges.

4 Troubleshooting

When a malfunction occurs, the TURBOVAC is braked and the failure is indicated; see following table.

The red LED FAILURE lights permanently and one green LED within the chain flashes.

After you have eliminated the cause of the failure, you can reset the malfunction signal with the STOP command (key or remote control).

Warning



Before you open the TURBOTRONIK, please first disconnect the mains power supply and disconnect the power cord. Since dangerous voltages may nonetheless occur, the unit should only be opened by a qualified electrician.

LED flashes	Symptom	Probable Cause	Recommended Corrective Action
No. 1 (below)	Linecord fault.	Motor connection line incorrectly connected. Motor connection line malfunctioning.	Check the motor connection line and connect it correctly. Replace the motor connection line.
No. 2	TURBOVAC is not supported by the TURBOTRONIK.	TURBOTRONIK and TURBOVAC incompatible. Loose contact in connection line.	Check the system. Repair the connection lines.
No. 3	The TURBOVAC has not attained the target speed within 10 minutes.	Forevacuum pressure $>10^{-2}$ mbar. Pump blocked. High vacuum pressure too high.	Check the forevacuum. Inform the Leybold after-sales service. Check the vacuum chamber.
No. 4	Speed below minimum.	Forevacuum pressure $>10^{-2}$ mbar. Pump blocked. High vacuum pressure too high.	Check the forevacuum. Inform the Leybold after-sales service. Check the vacuum chamber.
No. 5	Temperature in the TURBOTRONIK too high.	Frequent switching between acceleration and braking. Ambient temperature too high. Forevacuum pressure $>10^{-2}$ mbar.	Let the TURBOTRONIK cool down. Ensure an adequate ventilation. Operate the pump under normal load only.
No. 6	Temperature in the TURBOVAC too high or wrong coding.	Frequent switching between acceleration and braking. Poor cooling or cooling line interrupted. (coding error?) Excessive current in the output stage of the TURBOTRONIK; e.g. short-circuit.	Let the pump cool down and operate under normal load only. Check the cooling. Turn off the POWER switch on the TURBOTRONIK, remedy the fault and switch on again.
No. 7	Self-test	Overcurrent, short-circuit Strong mains interference System failure	Briefly switch off the TURBOTRONIK and then switch on again. Check the connections. Call the Leybold service department.
No. 8	Not used.		
No. 9	Wrong mains connection.	Mains voltage selector switch incorrectly set.	Set the mains voltage selector switch correctly; see Section 2.1.



LEYBOLD VAKUUM GmbH
Bonner Strasse 498 (Bayenthal)
D-50968 Köln
Tel.: (0221) 347-0
Fax: (0221) 347-1250
<http://www.leyboldvac.de>
e-mail: documentation@leyboldvac.de