

SuperSeal™ UHP DISS Cylinder Gaskets

Precision Machined Gasket for UHP CGA Connections

SPECIFICATIONS:

- Soft-Annealed Nickel 200 Material
- Fits 630 to 728 Series Cylinder Connections
- Recessed Sealing Surfaces
- Retaining Clip for Easy Installation
- Compliant with CGA-TB9-1993
- Labeled with Heat & Lot Traceability
- Hardness Max 105 Vickers / 75 R15T
- 5 Ra Maximum Surface Roughness
- Hot DI Cleaned and Hot N2 HEPA Dried
- 5 Mil Nylon Bagged for Moisture Protection

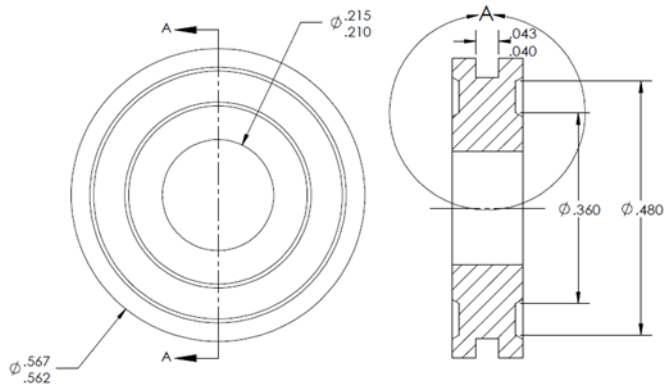

CGA/DISS SERIES	Material	Length Dimension	Width Dimension	Bore Dimension	Recessed Dimension
632 – 728	Nickel 200	.562 - .567	1.21 – 1.33	.210 - .215	.007 - .013



Using the finest quality materials, most advanced manufacturing practices, and ultrapure packaging processes, Critical Systems offers the premier gaskets for microelectronics industries.

Since 2000, Critical Systems, Inc. (CSI) has been supporting the breakthrough technologies of our customers with practical, innovative solutions that “surround” the process tool.

7000 West Victory Road · Boise, ID 83709 · (877) 572-5515 · Fax (801) 572-5304 · CriticalSystemsInc.com

***SuperSeal™* UHP DISS Cylinder Gaskets**

Usage & Handling Guidelines

- Safety is of the utmost importance. Always follow the safety recommendation of the site owner, the gas producer and the equipment manufacturer.
- A new gasket should be installed at each use. Used gaskets may cause damage to the toroids.
- Use gaskets only for 630/710 connections. The same gasket can be used for the entire series.
- Keep new gaskets in their protective package until installed.
- Inspect the threads and sealing surface prior to each use. Do not connect parts which appear to be damaged.
- Insert a gasket into the nipple by compressing its retaining clip and sliding the gasket into the nipple so that the open ends of the retaining clip are opposite the thumb notch access in the nipple.
- 630/710 connections are stamped with their CGA numbers. Always match these components before attempting to assemble.
- Anti-rotational slots in the valves and keys on the nipples are meant only to prevent rotation between sealing surfaces during assembly, when the normal clockwise tightening torque is applied to the CGA 630/710 nut. Torque applied directly to the nipple during or after make-up may damage the valve connection.
- Check before assembly that the gasket is retained by its clip in the nipple recess. Do not try to make a connection without a gasket. If back-purging is used prior to or during assembly, the gasket may be dislodged. To avoid this problem, minimal flows should be used when back-purging.
- Only use connecting nipples that have the anti-rotation device. This also applies to gas tight outlet caps when using metal gaskets.
- When removing gaskets, always use the notch provided. This will minimize the potential damage to the toroids in the nipple.
- Always use a torque wrench when tightening CGA 630/710 connections. The recommended torque value for these connections with a nickel 200 gasket is 35 ft-lbs. Excessive torque will damage the connection and possibly result in a hazardous condition.
- A made-up connection should be pressurized with inert gas and leak tested (using a suitable leak detector) prior to being put in service. If a leak is detected, the connection should be depressurized and remade using a new gasket and the recommended torque.
- Do not attempt to increase the torque in an effort to achieve a seal. If the leak is detected after the procedure has been repeated, the connection is to be considered damaged. Contact your gas supplier for further assistance.