

Parker Dual-Bed Nitrogen Generation Systems DB5-20

Installation, Operation, and Maintenance Manual

aerospace
climate control
electromechanical
filtration
fluid & gas handling
hydraulics
pneumatics
process control
sealing & shielding



ENGINEERING YOUR SUCCESS.

Parker Dual-Bed Nitrogen Generation Systems

Models DB-5, DB-10, DB-15, DB-20

Installation, Operation, and Maintenance Manual

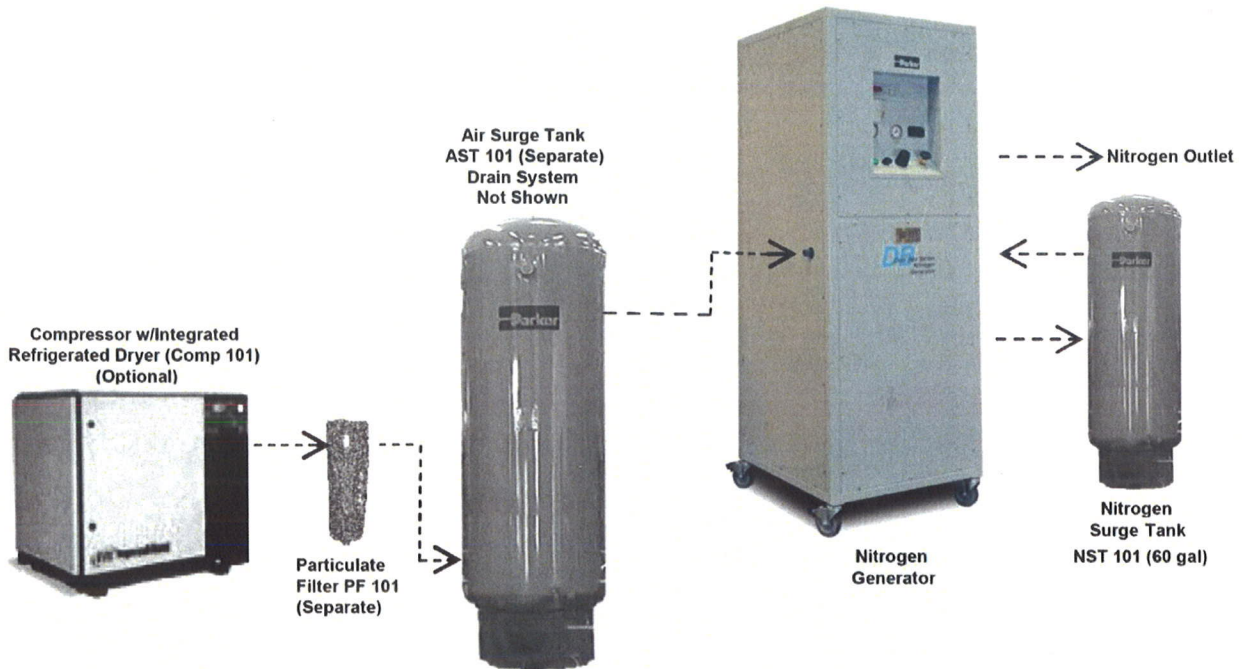

Figure 1: Typical Setup of the Parker Dual Bed Nitrogen Generator

⚠ CAUTION: Excessive oil or moisture levels in the inlet air will cause irreversible contamination to the Adsorption Vessel (CMS) material. If there is any indication or suspicion of excessive oil levels in the feed air (e.g., oil-saturated filter elements, dryer malfunction), find and correct problem(s) before installing Parker Dual-Bed Nitrogen Generators.

These instructions must be thoroughly read and understood before installing and operating this product. Failure to operate this product in accordance with the instructions set forth in this manual and by other safety governing bodies will void the safety certification of this product. For additional information refer to Warnings and Precautions section (page 41) of this manual or consult the factory for recommendations. If you have any questions or concerns, please call the Technical Services

Department at 1-800-343-4048 x2767, 8AM to 5PM Eastern Time or email at balstontechsupport@parker.com (North America only). Please have the four-digit serial number ready. For other locations, please contact your local representative.

The DB-5, DB-10, DB-15, and DB-20 PSA Nitrogen Generator Series are intended to produce nitrogen from compressed air through a system based on pressure swing adsorption. Any other use will not conform with the purpose of the DB unit. Parker Hannifin will not accept any liability for improper use.

Bulletin TI-DB5-20



Parker Hannifin Corporation
 Gas Separation and Filtration Division
 4087 Walden Ave.
 Lancaster, NY 14086
www.parker.com

Contents

Description	4
Installation	8
Operation	11
System Adjustment	12
Fuses	19
Oxygen Analyzer	22
Filter Maintenance	23
Process Valve Rebuild	24
Pilot Valve Maintenance	34
Spare Parts Ordering Information	37
Additional emergency spare parts	38
Expansion Kits	38
Warnings and Precautions	41
Troubleshooting and Service	42
Principal Specifications	44
Performance Data (nominal conditions)	48
Maintenance Log	50
Notes	52



Parker Hannifin Corporation
Gas Separation and Filtration Division
4087 Walden Ave.
Lancaster, NY 14086
www.parker.com

General Description

The Parker Dual-Bed Nitrogen Generators are completely engineered systems, which will convert a compressed air supply into 95-99.999% purity, compressed nitrogen. The units are based on state-of-the-art Dual-Bed Pressure Swing Adsorption (PSA) technology. The adsorption bed converts compressed air into a concentrated Nitrogen output stream.

Engineered System

The Parker Dual-Bed Nitrogen Generators include all the components required to convert compressed air into high purity nitrogen. The user need only connect a supply of clean, dry compressed air to the inlet of the Nitrogen generator, and then connect the outlet of the generator to the process requiring high purity nitrogen. The system can be broken down into four primary functional groups:

- Pre-filtration
- Nitrogen generation
- Final filtration
- Controls

NOTE: Nitrogen produced by PSA Nitrogen Generators contains Argon which is also inert. Therefore, when mentioning Nitrogen purities, the composition of the product gas is determined by the residual Oxygen content. Ex. 1% Oxygen in product gas is equivalent to 100%-1% = 99% (Nitrogen + Argon).

Description**Pre-filtration**

Refer to Figure 3. One high efficiency coalescing filter is incorporated into the nitrogen generator to protect the adsorption bed and valves from contamination. The coalescing filter is located inside the unit, just after the inlet air connection. It removes trace liquids and particulate matter from the incoming air supply. This filter is equipped with an automatic float drain to empty any liquids accumulated within the filter housing.



CAUTION: It should be noted that this filter is present for final filtration of the incoming air only. The air supplied to the system should be clean and dry prior to reaching these filters. Any accumulation of oil or moisture in these filters should be an indication of possible CMS contamination. The amount of liquid present and the duration of time will determine the amount of contamination to the CMS Bed.

Nitrogen Generation

Refer to Figure 3 and 4. The heart of the system is the pair of Adsorption Vessels loaded with Carbon Molecular Sieve (CMS). The CMS adsorbs Oxygen from compressed air, producing a Nitrogen stream, which is collected in the Nitrogen Surge Tank (NST 101). Essentially, one adsorption vessel will alternate between the adsorption and desorption phase. When one vessel (AV 101 or AV 102) is in its Adsorption Cycle, the other vessel is in its Desorption Cycle.

The cycling of the system is controlled by a PLC (Programmable Logic Controller), which sends electrical signals to solenoid valves. The solenoid valves in turn pneumatically actuate the process valves (controlling Air and Nitrogen flow). One of the two Inlet Air process valves (PV 101 or PV 102) is open, allowing air to enter the vessel set beginning its Adsorption Cycle. The corresponding



Parker Hannifin Corporation
Gas Separation and Filtration Division
4087 Walden Ave.
Lancaster, NY 14086
www.parker.com

Nitrogen process valve downstream (PV107 or PV108 respectively) is also open, allowing the Product Nitrogen stream to leave the vessel during the Adsorption process. At the same time, the Desorption Vent valve (PV 104 or PV 103) of the other vessel set is open, releasing to the atmosphere, the Oxygen-rich gas from the vessel set undergoing the desorption process. At the end of the Adsorption Cycle of a vessel (approx. 1 minute), the pressures in the two sets of vessels are allowed to equalize (PV 105 and PV 106 open, while all feed, product, and desorption valves are closed). Then the vessel which had been in its Adsorption Cycle will undergo Desorption, and vice versa.

Since one Adsorption Vessel is essentially always in a production state (with the exception of the 4-second equalization period), a continuous flow of Nitrogen is produced. The system can be equipped with a continuous Oxygen analyzer to monitor the product purity. After the initial startup, the Nitrogen Generator is designed to operate continuously.

Final Filtration

The final filter (AF101) on the nitrogen generator is a Parker/Balston 6000 Series Stainless Steel Grade SA (sterile air) filter. The final filter removes particulate contamination with an efficiency of 99.9999% at 0.01 micron, assuring the user of clean high purity Nitrogen. The final filter is located on the right-hand-side, in a DB5 and DB10, and at the bottom-left, in a DB15 and DB20 (see Figure 2B).

Flow/Pressure Controls The flow and pressure controls are shown in Figure 2, and are comprised of:

- an outlet pressure regulator (PRV 101)
- outlet pressure gauge (PI 102)
- outlet flow meter (FE 101), and
- flow controller (PCV 101)

Proper use of these controls will assure the user of a 95% to 99.999% purity Nitrogen outlet stream (See note below). The outlet pressure regulator and gauge are used to set and monitor the Nitrogen outlet pressure from the generator. The flow controller and flow meter are used to set and monitor the Nitrogen outlet flow rate. The flowmeter is set to read in standard cubic feet per hour (SCFH) but may be programmed to read in standard cubic feet per minute (SCFM) by the user. Flows at various purity levels are shown on page 42 of this manual.

The system will produce higher purity Nitrogen (lower O₂ content) at lower flow rates; conversely, the same system will produce lower purity Nitrogen (high O₂ content) at higher flow rates. At higher flow rates, there will also be greater fluctuations in the Nitrogen Surge Tank pressure as the Dual-Bed goes through a full cycle of both Adsorption and Desorption phases.

NOTE: Purities of 99.9 to 99.999% require an oxygen analyzer upgrade and must be sampled directly from the Nitrogen Surge Tank (NST 101) using copper or stainless steel tubing.

Electrical Controls

The electrical control on the Parker Dual-Bed is an "O/I" switch. The "O/I" switch is located on the lower left side of the control panel (see Figure 2). This switch is used to start the Nitrogen generator through its normal cycle.



Parker Hannifin Corporation
Gas Separation and Filtration Division
4087 Walden Ave.
Lancaster, NY 14086
www.parker.com

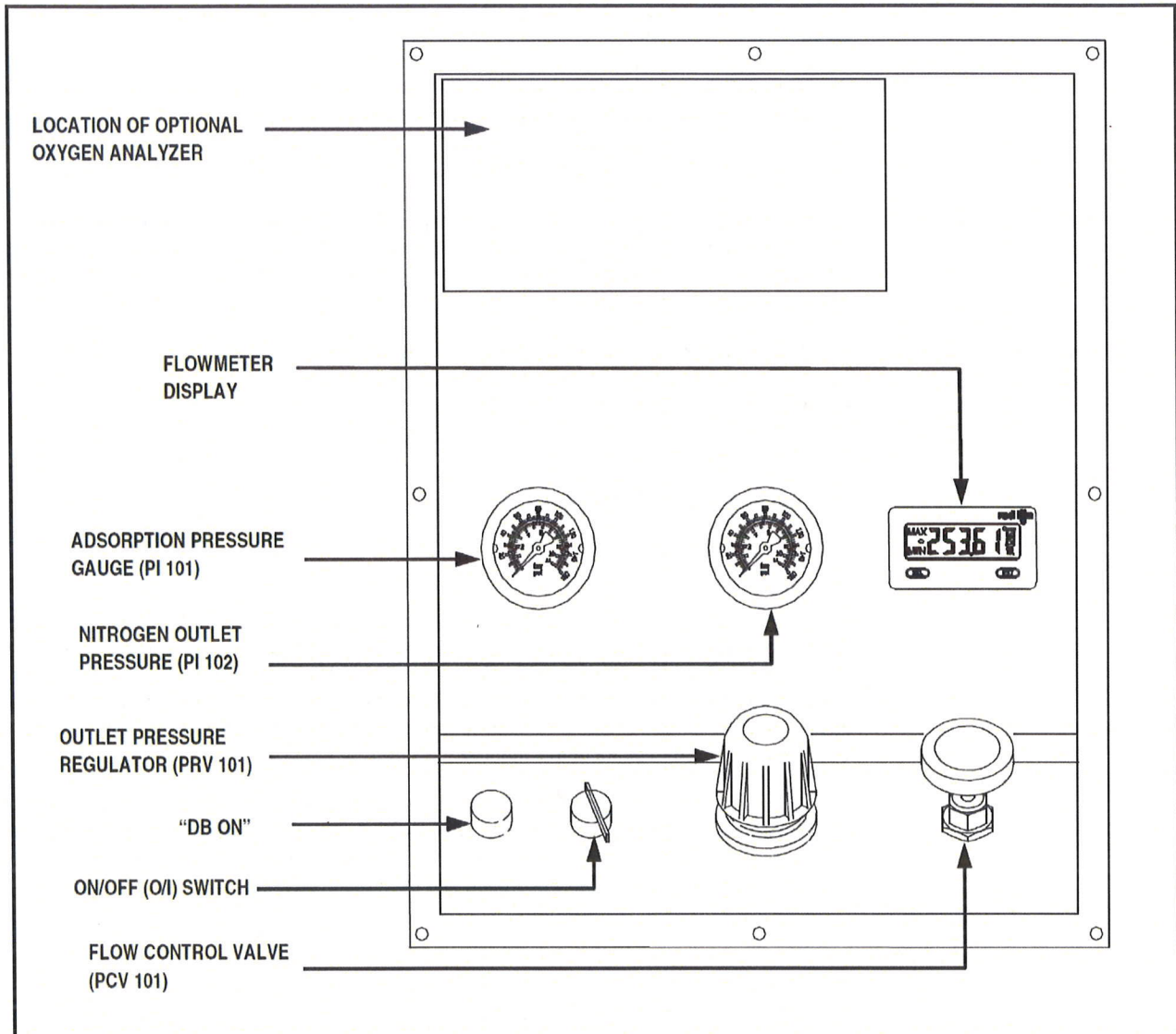

Figure 2A: Typical Control Panel Layout



Parker Hannifin Corporation
Gas Separation and Filtration Division
4087 Walden Ave.
Lancaster, NY 14086
www.parker.com

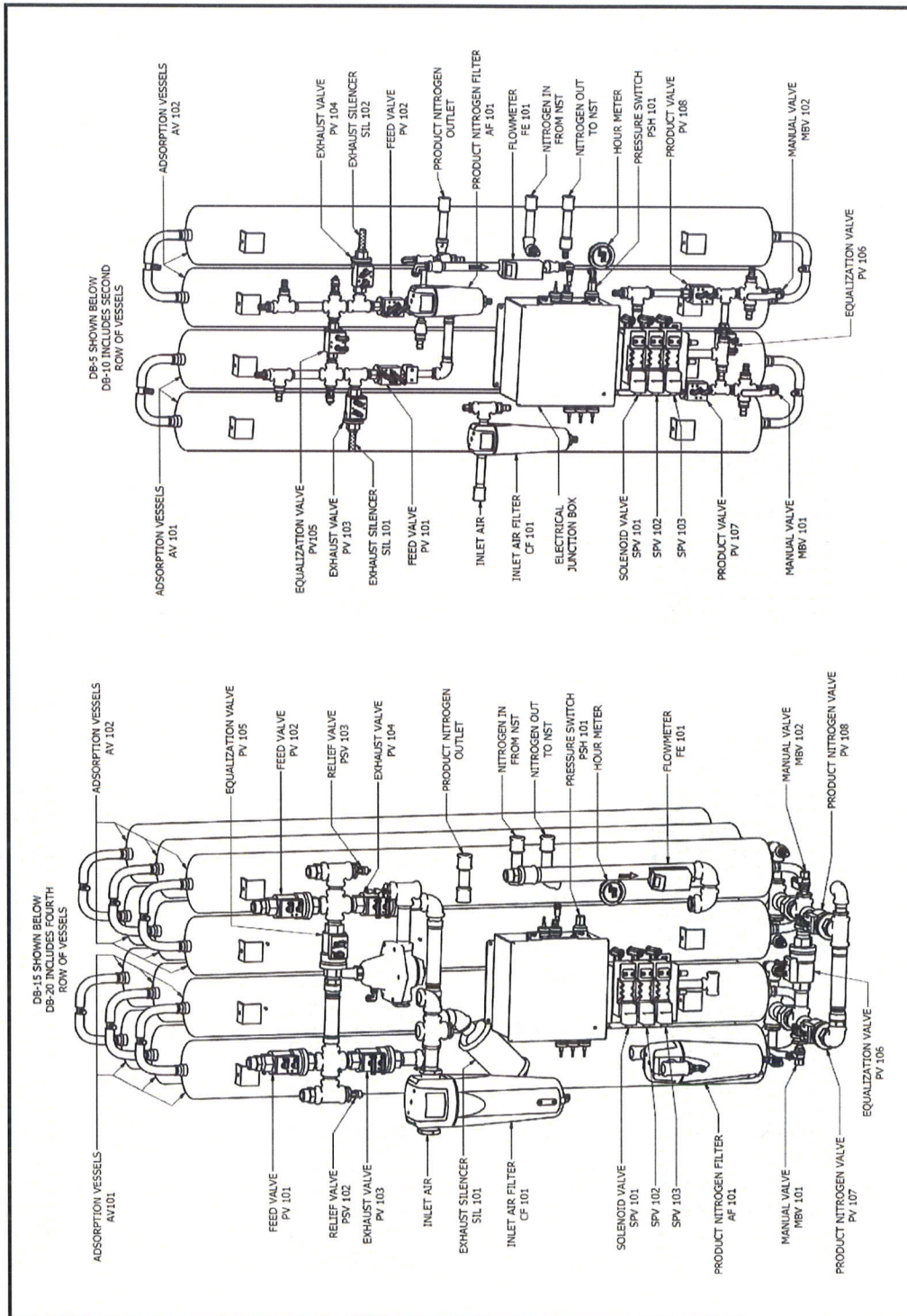

Figure 2B: Instrumentation Diagram



Parker Hannifin Corporation
 Gas Separation and Filtration Division
 4087 Walden Ave.
 Lancaster, NY 14086
 www.parker.com

Installation

General

The Parker Nitrogen Generation System is a freestanding unit. On each generator model, the air inlet port is located on the left side and the nitrogen outlet port is located on the right side of the unit. Use connectors that will withstand 150 psig and the maximum flow rate of the system to connect to the Nitrogen generator.

The nitrogen storage tank that is included with the system must be connected to the appropriate ports (labeled at the factory) located on the right-hand-side panel (See Figure 3) of the generator cabinet using the supplied hose assemblies. Always transport the DB generator in an upright position when using a forklift.

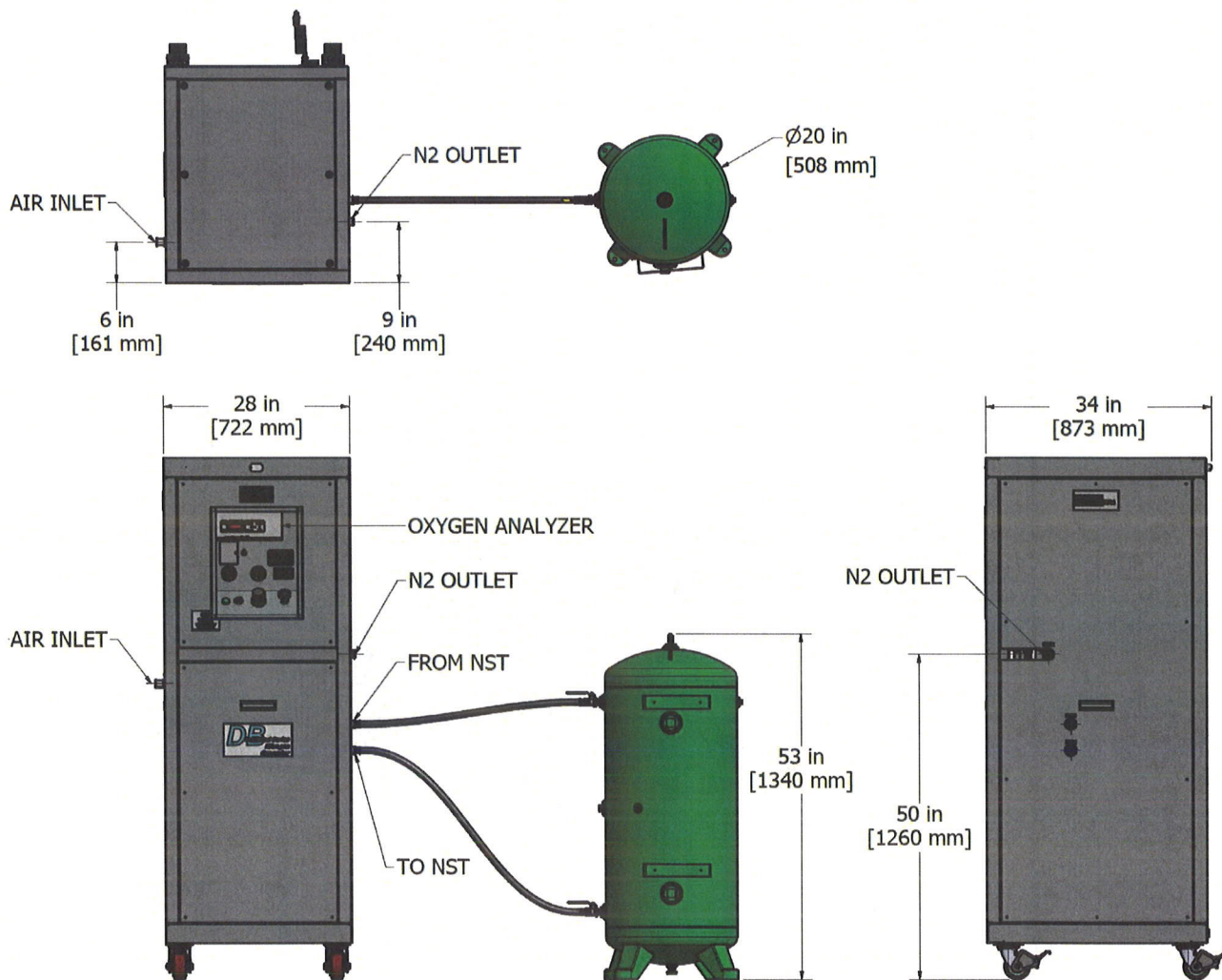

Figure 3: Typical DB connections and overhead view (DB5/10 shown)



Parker Hannifin Corporation
 Gas Separation and Filtration Division
 4087 Walden Ave.
 Lancaster, NY 14086
 www.parker.com

NOTE: The right-hand side of the nitrogen generator cabinet has three ports. The lowest two ports must be connected to the nitrogen storage tank, and the top port is for the nitrogen application. Contact the Technical Services Department at 410-636-7200 for further inquiries.

Location

The DB-5, DB10, DB-15, and DB-20 are intended for indoor use only and should be located in an area where the ambient temperature is between 40°F and 95°F (4°C and 35°C). Installation of the unit in an area where the ambient temperature exceeds 95°F (35°C) or falls below 40°F (4°C) may affect the performance and/or life of the system and void the warranty. The environment surrounding the nitrogen generator should also be vibration-free, dry, and adequately ventilated. The generator creates an oxygen-rich permeate stream which may pose a flammability problem in an oxygen sensitive environment.

⚠ CAUTION: Nitrogen is nontoxic and largely inert. It can act as a simple asphyxiant by displacing oxygen in air. Inhalation of Nitrogen in excessive concentrations can result in unconsciousness without any warning symptoms such as dizziness, fatigue, etc. Install the generator in a well-ventilated area.

⚠ CAUTION: An oxygen-rich stream is released from the adsorption vessels through the silencer. Oxygen enriched air leads to increased risk of fire in the event of contact with flammable products. Ensure that there is adequate ventilation at all times. Do not install the Dual Bed Nitrogen Generator where explosive mixtures may occur.

Utilities

Compressed Air - The Parker Nitrogen Generation System requires a source of clean, dry compressed air for optimal operation. The compressed air should be of instrument quality and supplied at a pressure of 110 psig minimum to 140 maximum. If the compressed air supply pressure is less than 110 psig, purities and flows will vary from those shown on the Nitrogen Flow tables provided in the **Principal Specifications** section of this manual. At air supply pressures greater than 110 psig, the performance of the generator will be optimal. Consult the factory for flows and purities at pressures higher or lower than 110 psig. If the incoming air pressure is greater than 140 psig, the system may be damaged and the warranty will be void. The supply air should also be at room temperature and relatively free of water, compressor oil, hydrocarbons, and particulate matter. Parker recommends a dedicated compressed air system which includes a compressor, an after cooler, and a refrigerated dryer to supply compressed air at a dew point 40°F or better, a water separator, and final filtration. The compressor should provide enough airflow to prevent excessive pressure drops during the cycling of the PSA beds. Compressed air consumption rates at different outlet flows and purities are detailed in the **Principal Specifications** section at the end of this manual. An air surge tank is necessary to store air for peak air demand. An existing central bank may be used, or if a dedicated air compressor is being used for the DB, a properly sized surge tank will be required.

NOTE: It is highly recommended that a qualified service technician from the compressor company set-up the feed air compressor when purchased with the package. Serious damage to the air compressor may result if improperly set-up.

⚠ CAUTION: Excessive quantities of water, compressor oil, hydrocarbons, or particulate in the compressed air supply will contaminate the CMS material and valves. If contamination of the system occurs as a result of an inferior compressed air supply, nitrogen purity specifications will not be met and the warranty will be void.



Parker Hannifin Corporation
Gas Separation and Filtration Division
4087 Walden Ave.
Lancaster, NY 14086
www.parker.com

Power - A 120 VAC/60 Hz, 15 amp power source will be required to energize the Parker Dual-Bed Nitrogen Generation Systems.

Piping - The inlet air and Nitrogen outlet piping should adapt to the inlet and outlet port properly. All piping and fittings used with the Nitrogen generator should be clean and rated to 150 psig minimally.

Drain Lines - The 1/4" plastic drain lines from the optional prefilter (PF 101 - Fig. 1) should be piped away to an appropriate disposal container. The drainage, consisting primarily of water and compressor oil, should be disposed of properly according to local regulations. One-quarter inch tubing can be used for the condensate drains on the Nitrogen Generator. Although no condensate should normally collect in these filters, the tubing attached should be run separately into the proper collection disposal container.



Parker Hannifin Corporation
Gas Separation and Filtration Division
4087 Walden Ave.
Lancaster, NY 14086
www.parker.com

Operation

Pre-Start Procedure

The DB unit requires approximately two hours of startup time to achieve rated purity (longer if higher purities are desired). Nitrogen generated during this period should be vented to atmosphere to avoid contaminating downstream processes. After the inlet and outlet piping has been connected to the generator, plug the power cord into a 120 VAC/60 Hz power source. If high purity Nitrogen is already stored in Nitrogen Surge Tank, follow Normal Start Up procedure.

Initial Start-Up

Follow the steps below after installation or any maintenance work on the DB unit.

1. Check to ensure the power cord is plugged into a properly protected 120 VAC, 1-phase, and 60 Hz power receptacle.
2. Check to ensure that a properly protected power connection has been made to the compressor according to the manufacturer's instructions (**IMPORTANT: Determine voltage specification of compressor. Follow compressor manufacturer's instructions, supplied with compressor, for proper set-up and operation**). Connect compressor piping AND particulate filter (PF 101) to air surge tank (AST 101) according to diagram in Figure 1. Set compressor to unload at 125 psig and load at 110-115 psig.
3. Connect air surge tank (AST 101) to DB nitrogen generator as shown in Figure 1.
4. Secure all filter elements.
5. Connect NST101 (nitrogen surge tank) to the generator as shown in Figure 1. Be sure the petcock on the bottom of the NST is fully closed as a small leak can cause substantial degradation in the performance of the unit.
6. Turn on feed air and allow pressure to build up in AST 101.



CAUTION: The user must read the oxygen analyzer manual for proper operation and important information about the device.

7. Optional: If equipped, calibrate the Oxygen Analyzer by switching the "Calibrate/Generate" valve (TSV 101) to the "Calibrate" position. Adjust the "Span" potentiometer such that the display reads a steady "20.9" (amount of oxygen in atmospheric air). Once calibrated, return to the "Generate" position. Refer to the Oxygen analyzer technical manual for more information.
8. Switch the "O/I" to the "I" position.
9. The generator will begin its adsorption cycle. During the adsorption cycle the Nitrogen Surge Tank will begin to pressurize.
10. Once there is sufficient pressure in the nitrogen surge tank (NST 101), adjust the Outlet Pressure by turning pressure regulator PRV 101 until gauge reads desired setting.
11. Open PCV 101 and allow a small amount of nitrogen to purge into the room.
12. Verify outlet pressure reading. Adjust if necessary.



Parker Hannifin Corporation
Gas Separation and Filtration Division
4087 Walden Ave.
Lancaster, NY 14086
www.parker.com

 **CAUTION: Nitrogen is nontoxic and largely inert. It can act as a simple asphyxiant by displacing Oxygen in air. Inhalation of Nitrogen in excessive concentrations can result in unconsciousness without any warning symptoms such as dizziness, fatigue, etc. Install the generator in a well-ventilated area.**

13. After 2 hours of undisturbed operation or once the Oxygen content is at acceptable levels, close PCV 101 and connect outlet port to application.

Normal Start-Up

1. Set the inlet air pressure to between 110 psig and 125 psig.
2. Allow air to pressurize up to the inlet air filter.
3. Turn the "O/I" switch to the "I" position.
4. Calibrate the Oxygen Analyzer if equipped.
5. Allow the DB to cycle for approximately 3 minutes.
6. Slowly open MIV 101 and MIV 102 at NST 101.
7. Adjust the Outlet Pressure and Flow Rate based on individual system requirements (refer to **System Adjustment** section below).

System Adjustment

After the Parker Nitrogen Generation System has been energized and pressurized, determine the outlet pressure and purity of Nitrogen required for the application. Set the flow parameters as follows:

1. **Pressure** - To adjust the outlet pressure from the generator, turn the outlet pressure regulator until the outlet pressure gauge displays the desired outlet pressure.

NOTE: Not all flows are available at all pressures.

2. **Flow** - Set the outlet flow after setting the outlet pressure, by turning the flow control valve until the desired flow meter reading is displayed on the flow meter display. Avoid exceeding the output capacity of the generator. If outlet capacity is exceeded, the Nitrogen generated will not meet purity specifications.



Parker Hannifin Corporation
Gas Separation and Filtration Division
4087 Walden Ave.
Lancaster, NY 14086
www.parker.com

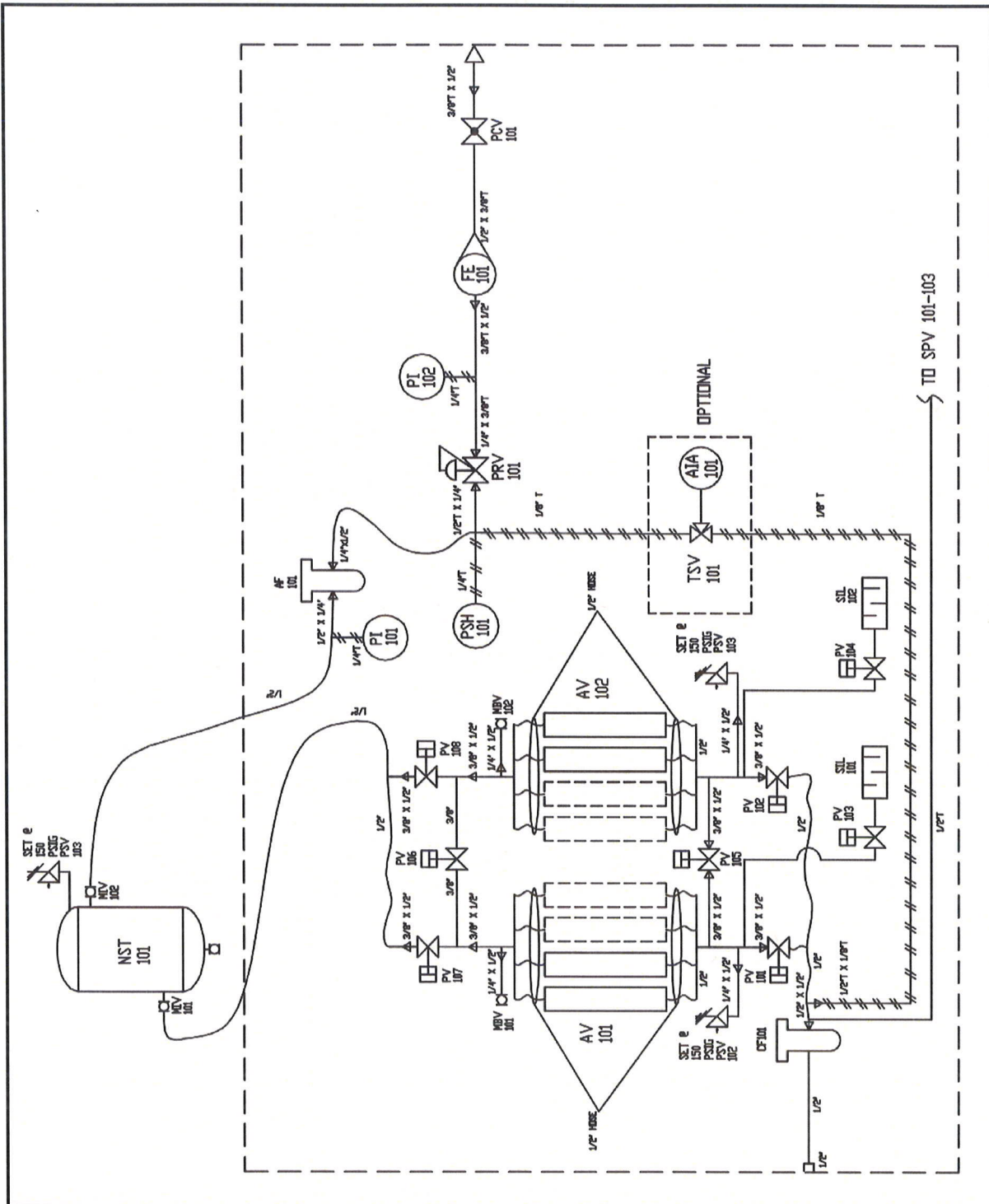

Figure 3: Typical Process Flow Diagram



Parker Hannifin Corporation
 Gas Separation and Filtration Division
 4087 Walden Ave.
 Lancaster, NY 14086
 www.parker.com

Evaluation

The performance and operating conditions of the Nitrogen Generation System should be monitored on a routine basis, as dictated by the application. This routine system check should include:

- confirming Nitrogen purity stability,
- adjusting flow meter reading (if necessary)
- confirming adsorption vessel cycling pressures
- checking outlet pressure

If any of these readings have changed significantly from their original settings, adjustments must be made as described in the **System Adjustment** section of this manual. If the Nitrogen purity must be altered during operation of the system, allow approximately 1 hour for the purity to stabilize.

Temperature Considerations

The data represented in this manual is based on an ambient operating temperature of 77°F (25°C). The standard unit is designed to operate in the temperature range of 40°F to 95°F (4°C to 35°C). Please consult factory if the ambient temperature in the generator location will be outside this range.

Shutdown

There are two different shutdown procedures for the Parker Nitrogen Generation System. The Normal Shutdown procedure should be followed for filter maintenance, oxygen analyzer maintenance, and temporary operational shutdowns (i.e. overnight, weekends).

After a Normal Shutdown, a supply of high purity Nitrogen gas will remain in the receiver tank and system start-up time will be reduced when the generator is restarted. The Total Shutdown is normally necessary only for long term storage or for preparing the unit for shipment. After a Total Shutdown, the Nitrogen receiver is empty; therefore, the start-up time for the generator will be approximately 2 hours (Follow Initial Start Up procedure).

Normal Shutdown

1. Turn the "O/I" switch to the "O" position, off.
2. Close both manual ball valves at the nitrogen surge tank.
3. Isolate system from feed air source and process.
4. Depressurize the system by opening MBV 101 & 102 to bleed trapped gas from both sets of vessels. This can be accomplished by opening both valves slowly until depressurized. Open manual bleed valves and drain valves found on the filter housings.

Total Shutdown

1. Perform Normal Shutdown procedure.
2. Empty the Nitrogen receiver by opening the 2-way valve beneath the receiver tank.
3. Remove power from the unit (unplug power cord).

 **CAUTION: Pressure will remain in the adsorption vessel once the desorb valve is closed. DO NOT ATTEMPT TO PERFORM MAINTENANCE ON VALVES OR FILTERS WITH THE ADSORPTION VESSEL PRESSURIZED.**



Parker Hannifin Corporation
Gas Separation and Filtration Division
4087 Walden Ave.
Lancaster, NY 14086
www.parker.com

NOTE: It is normal for the adsorption vessels to slowly pressurize even when system is shut down. If maintenance is required, isolate unit from air system and process. Bleed remaining pressure in the system by opening the bleed valves on the filters, MBV 101 and 102 to bleed both sets of vessels, and Manual Drain Valve (MDV 101) on Nitrogen Surge Tank (NST 101).

All maintenance activities should be performed by trained personnel using reasonable care.

The DB unit must be de-energized and depressurized before performing any maintenance procedures.

Stand-By Pressure Switch Setting

For the Dual-Bed nitrogen generator to switch to stand-by mode, the pressure switch (PSH 101) has to remain in closed (changed state) position for 10 minutes. This means that the pressure switch has to be set just below the lowest pressure point in the nitrogen surge tank during no flow. Refer to the electrical diagram (Figure 5) and Figure 6. If the pressure switch is not set below the lowest pressure reading in the nitrogen tank **during no-flow condition** PSH 101 will open during the nitrogen tank pressure swing before 10 minutes has elapsed and the PLC will not set the unit to stand-by. The pressure switch is located inside the electrical junction box. A flat head screw driver is required to turn the adjustment screw. Take great care in using tools around live terminals.

NOTE: The stand-by feature should not be used in low flow/high purity applications as the pressure switch will not properly cycle under these conditions.

NOTE: During pressure switch adjustment, do not make any changes to the feed air system. If feed air supply has to be modified, it should be done prior to setting the pressure switch on the DB Nitrogen Generator.

NOTE: There may be a spike in oxygen content when the unit switches out of stand-by. It may be necessary to run the unit for up to 30 minutes to allow oxygen content to stabilize before flowing the product nitrogen into the application.

To set the standby feature of the DB unit follow the steps below.

1. With the DB unit cycling normally, close the outlet product control valve (PCV 101).
2. Allow the nitrogen generator to cycle completely four to five times and the nitrogen tank to pressurize.
3. Locate pressure switch inside main control panel.
4. Turn the adjusting screw counter-clockwise until the moving contact in the pressure switch just touches the bottom contact (closed position). Note that X1 in the PLC is illuminated. X1 lamp is illuminated when the pressure switch is in the closed position. If the switch is already closed, turn the adjusting screw clockwise until the contacts no longer touch. Then turn the adjusting screw counter clockwise until the switch closes. Refer to Figure 6.

NOTE: It is important to stop turning the screw immediately when PSH 101 changes to the closed position. Continuing to turn after the changed state sets the pressure switch lower than what is in the nitrogen surge tank.



Parker Hannifin Corporation
Gas Separation and Filtration Division
4087 Walden Ave.
Lancaster, NY 14086
www.parker.com

5. Let the nitrogen generator undergo further cycling (no flow - PCV 101 closed). Observe the pressure switch contacts or X1 on the PLC.
6. If the pressure switch switches back to the open position (bottom contact not touching and X1 not illuminated) during DB cycling with no flow, turn the adjusting screw further in a counter-clockwise direction until the pressure switch remains in the closed position (Input X1 illuminated) throughout the DB pressure swing cycles.
7. Once the pressure switch stays in the closed position throughout the DB cycling process, it is properly set.
8. After ten minutes have passed with the pressure switch in the closed position continuously, the nitrogen generator will go into stand-by mode, and the green "DB On" light will flash.

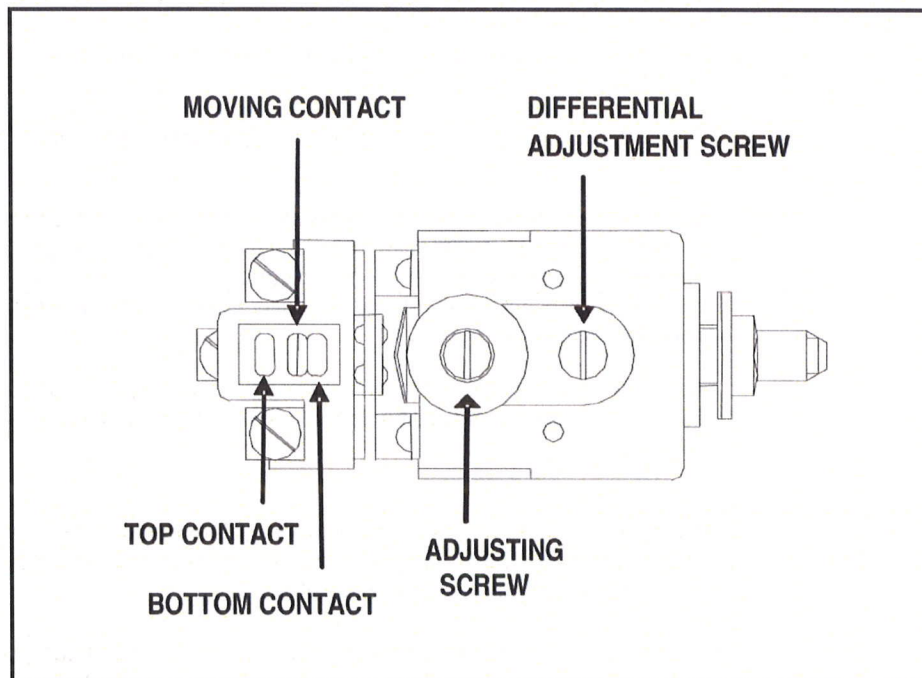

Figure 5: Pressure Switch

Resuming Flow

For automatic start-up out of stand-by mode, open the flow control valve to produce the normal flow rate. Once the pressure drops below the setting of the pressure switch (PSH 101) the nitrogen generator begins to resume pressurization and cycle normally.

Verification

It is important to verify that the pressure switch does not stay in the closed position for 10 minutes **during normal flow conditions**. If that is the case, then the pressure switch is set too low, and the nitrogen generator will go into stand-by during normal flow conditions (especially at higher purities).

1. After setting the pressure switch, open PCV 101 to produce the normal nitrogen flow rate.
2. Adjust PRV 101 to the proper outlet pressure required by the process. Readjust PCV 101 if necessary.
3. While the DB unit undergoes the normal cycling process, observe the pressure switch and Input X1 on the PLC.
4. If the pressure switch closes (X1 illuminated), ensure that it **will** change state throughout the DB cycling process (i.e. X1 should switch on and off, but should not stay on for 10 minutes). If it does not change state, the unit will go into standby (pressure switch is set too low). If this is the case, the adjustment screw will require a minor clockwise adjustment until the switch is operating as required.
5. As a final check, turn off the flow and observe that the unit will go into standby. Then, turn the flow on and make sure it operates normally out of standby. At this point, the switch is set correctly.

NOTE: Subsequent changes in the feed air system may interfere with the current pressure switch operation. After making any necessary changes in feed air pressure, check for proper pressure switch operation.

NOTE: The stand-by feature should not be used in low flow/high purity applications as the pressure switch will not properly cycle under these conditions.



Parker Hannifin Corporation
Gas Separation and Filtration Division
4087 Walden Ave.
Lancaster, NY 14086
www.parker.com

Fuses

The most likely cause of a complete failure of electrical power is a blown fuse. Fuses for the main unit are located in the rear of the machine, near the bottom. To access the fuses, remove the power cord and gently pry open the fuse block cover plate as shown in Figure 7.

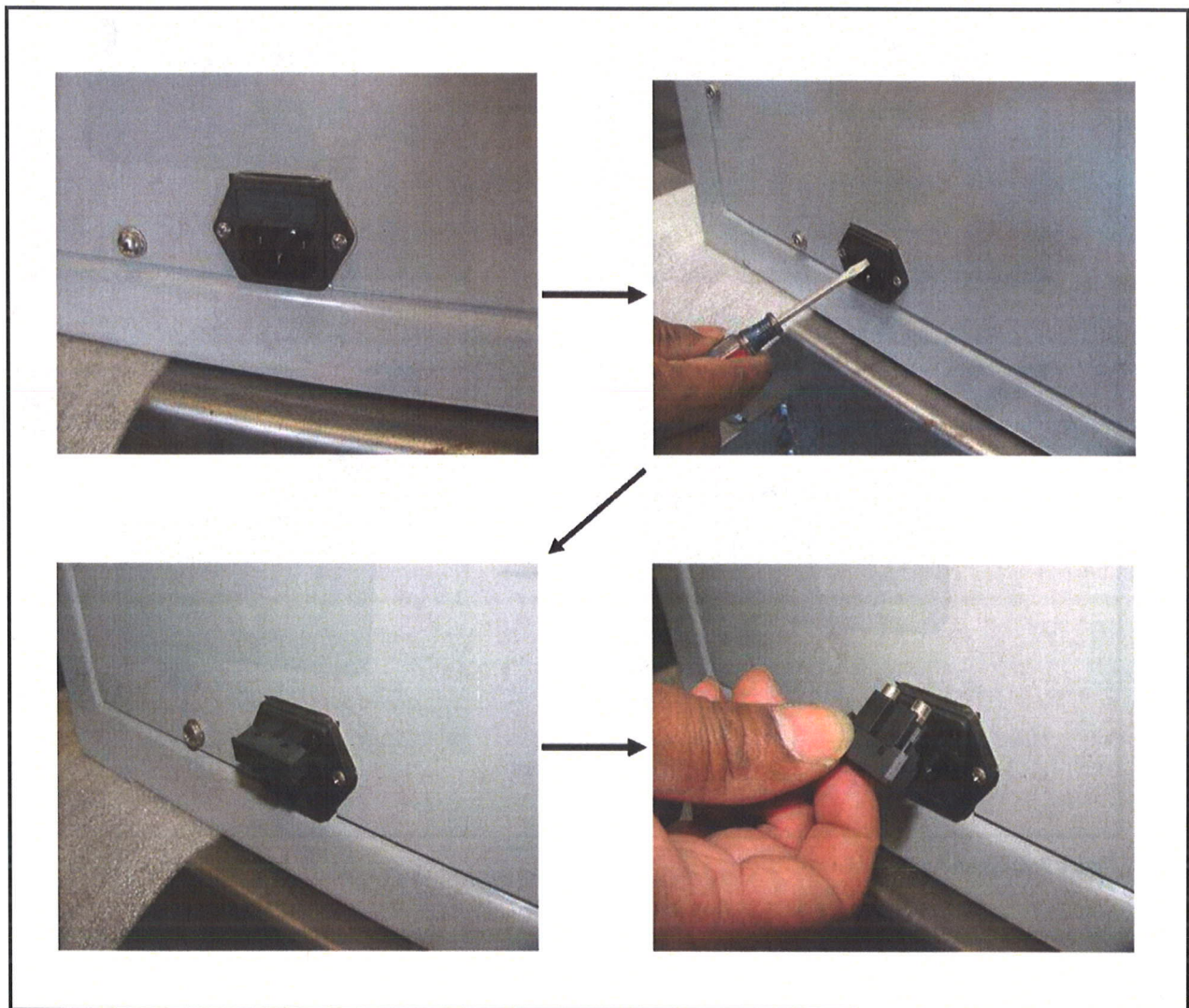

Figure 6: Main Fuses

1.5 AMP
250 VOLT



Parker Hannifin Corporation
Gas Separation and Filtration Division
4087 Walden Ave.
Lancaster, NY 14086
www.parker.com

Fuses for the optional Balston O2 analyzer are located inside the unit. Remove the lower front access panel and replace the fuses as necessary as shown in Figure 8.

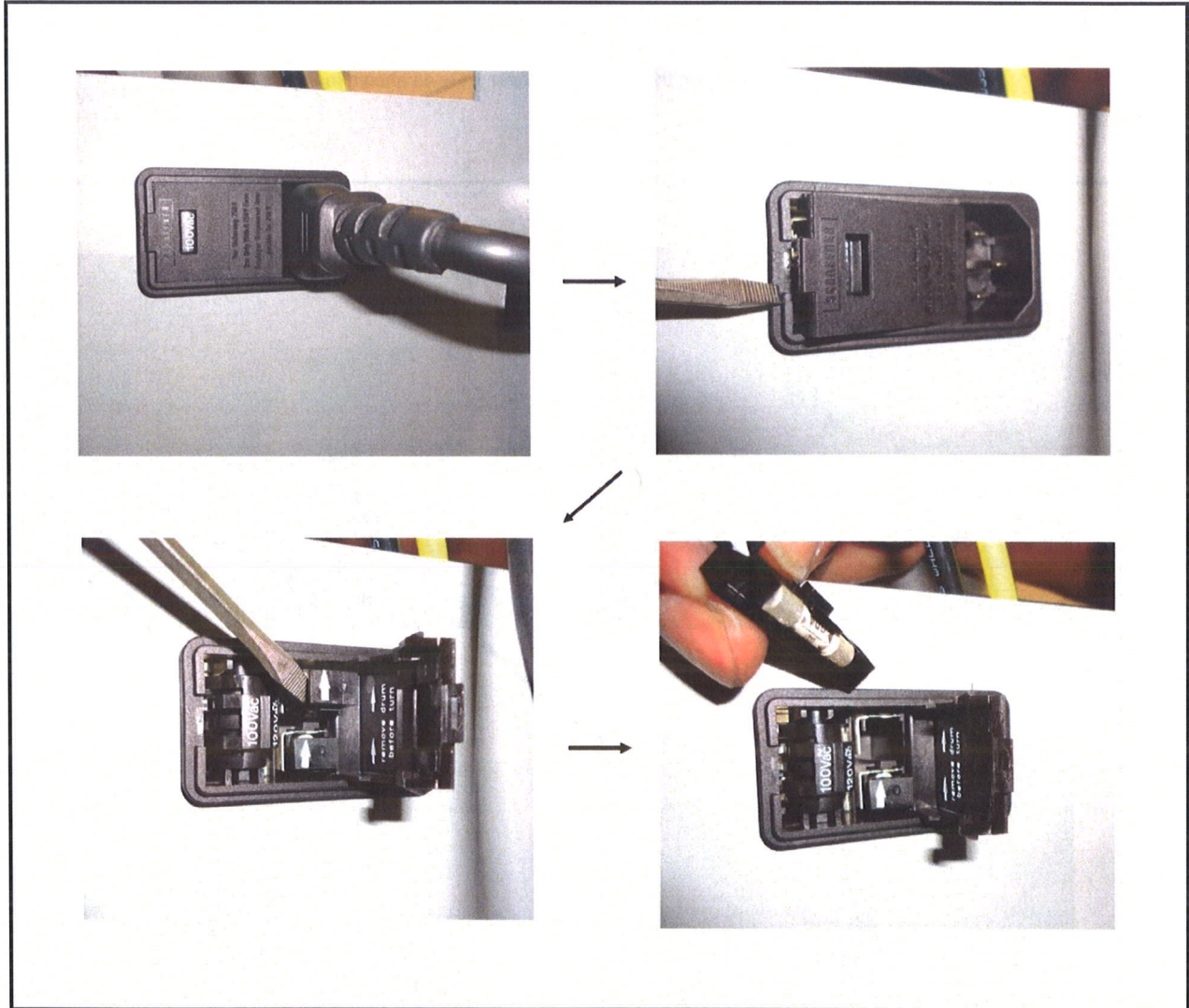













Figure 7: Oxygen Analyzer Fuses

Generator Maintenance Schedule

The fuel cell in the oxygen analyzer degrades over time and should be replaced approximately once per year, depending on the make and manufacturer of the analyzer. If large adjustments are required to calibrate the analyzer and calibration cannot be achieved, or if the reading continues to fall to zero, then the fuel cell needs to be replaced. After cell replacement, the proper calibration procedure must be performed.

Maintenance Required		Typical Recommended Maintenance Interval			
		Based on 52 weeks, 5 days a week, 8 hrs a day			
Component	Operation	Daily	520 hrs (3 m)	1040 hrs (6 m)	2080 hrs (12 m)
Generator	Check status indicators on control panel				
System	Check inlet air quality, pre-filter for contamination and drain operation				
Generator	Check for air leaks				
Generator	Check pressure gauges during purging for excessive back pressure				
Generator	Check condition of electrical supply cables				
Generator	Confirm cyclic operation				
Filtration	Replace pre and post filtration				
Generator	Replace/Calibrate oxygen sensor (if applicable)				
Generator	Service/replace process valves				
Generator	Inspect/service pilot valves				



Oxygen Analyzer

The fuel cell in the oxygen analyzer degrades over time and should be replaced approximately once per year, depending on the make and manufacturer of the analyzer. If large adjustments are required to calibrate the analyzer and calibration cannot be achieved, or if the reading continues to fall to zero, then the fuel cell needs to be replaced. After cell replacement, the proper calibration procedure must be performed.

Parts

Ensure that the replacement fuel is the correct model for the unit. The table below details the type of fuel cell needed for each type of oxygen analyzer:

Replacement Oxygen Monitor Fuel Cells	
Parker/Balston 72-730 (Standard Units)	72695
Advanced Instruments % Oxygen Analyzer	GPR-11-60-4
Advanced Instruments Trace Oxygen Analyzer	GPR-12-333

Tools Required

Phillips screwdriver
Calibrating tool or jewelers flathead screwdriver (for Parker/Balston Oxygen Analyzer)

Procedure

Consult proper oxygen analyzer manual (shipped with DB unit) for steps to replace fuel cell and calibrate analyzer.

Oxygen analyzer alarm contacts

The O₂ analyzers supplied with the DB5-20 series have external alarm contacts that can be wired by the customer in the field. These are dry contacts that may be used for purposes as determined by the user. The connection points are high on the rear panel of the unit (see Figure 9).



Parker Hannifin Corporation
Gas Separation and Filtration Division
4087 Walden Ave.
Lancaster, NY 14086
www.parker.com

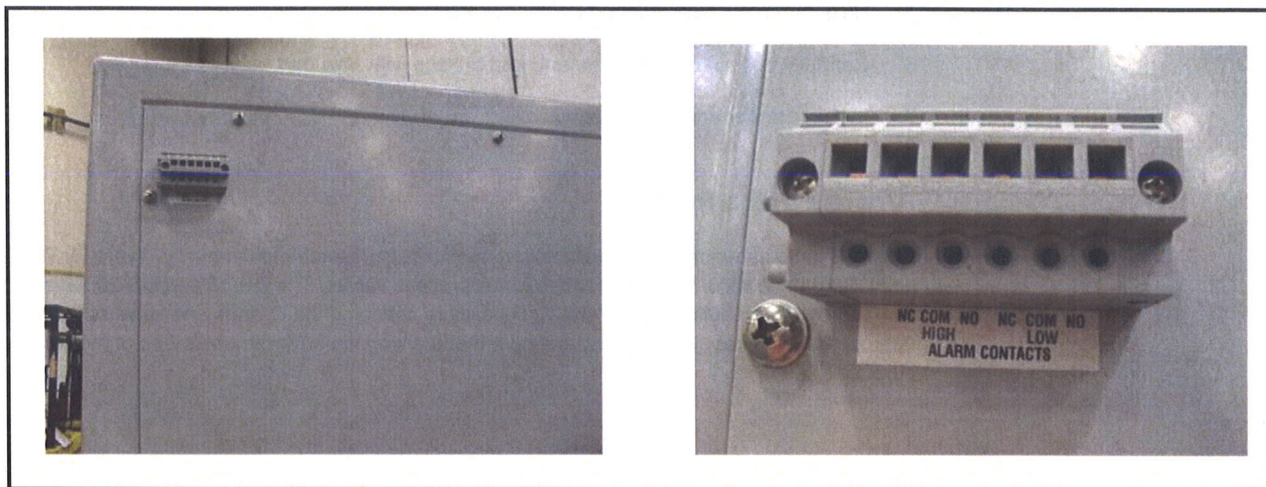

Figure 8: Oxygen Alarm Contacts

There are six connection points. The three on the left are for the high alarm and the three on the right are for the low alarm. When an alarm is not activated there will be continuity between the COM and the NC terminal of either contact. When an alarm is activated there will be continuity between the COM and the NO terminal. These alarm set points are adjustable on the O₂ analyzer itself.



CAUTION: All maintenance should be done with the system power disconnected and fully depressurized. Failure to do so can cause serious injury.

Filter Maintenance

The coalescing filter is located inside the unit just after the inlet air connection. This filter is present for final filtration of the incoming air only. Any accumulation of oil or moisture in these filters should be an indication of possible CMS contamination. The final filter, located on the right hand side of the unit, removes particulate contamination with an efficiency of 99.9999% at 0.01 micron to ensure high purity product Nitrogen output. **The two filter elements on the DB unit should be inspected every 520 operating hours and replaced if necessary. Otherwise, replace the elements every 1,040 hours. Reference the on-board hour meter (see Figures 2B and 18) for elapsed operation time.**

NOTE: Make sure that system is depressurized.

Procedure

Refer to Figure 3.

1. Remove lower front access panel
2. Securely hold bottom portion of filter housing.
3. Push up gently against top portion, and twist counterclockwise (opposite direction of LOCK arrow).
4. Remove filter housing.



Parker Hannifin Corporation
Gas Separation and Filtration Division
4087 Walden Ave.
Lancaster, NY 14086
www.parker.com

5. Unscrew round filter element retainer at the bottom.
6. Carefully pull out old filter element, and replace with new part.
7. Install fastener and filter housing.

Process Valve Rebuild

Each DB unit has eight process valves that need timely maintenance annually. Typically The DB-5 and DB-10 have six 3/8 inch and two 1/2 inch process valves. The DB-15 and DB-20 have eight 1-inch valves. The rebuild process mainly consists of changing the O-rings and valve seats. Order the appropriate valve rebuild kit, and make sure that the working environment is free of moisture and other contaminants.

Parts

	Description	Part number	Quantity
DB5 and 10	Process valve rebuild kit (3/8 inch)	RKVA037VV	6
	Process valve rebuild kit (1/2 inch)	RKVA050VV	2
DB15 and 20	Process valve rebuild kit	RKVA100VV	8

Tools

Phillips screwdriver	Masking or painter's tape	PTFE pipe paste
Flathead screwdriver	thin-tip permanent marker	White Lithium Grease
5/32 hex key	7/8 wrench	PTFE tape

Procedure

Remove the side panels and the lower front access panel of the nitrogen generator to access the valve manifolds. If the air inlet and product nitrogen outlet ports are hard-piped and the side panels cannot be removed, then the front upper panel has to be removed for access. This is a rather involved procedure and it is recommended that if at all possible, the access be done by removing the side panels. If it is absolutely necessary that the front upper panel be removed, please contact the factory for detailed procedures.

Mark all tubing and hose connections before removal to ensure correct reassembly.

 **CAUTION: Pressure will remain in the adsorption vessel once the desorb valve is closed. DO NOT ATTEMPT TO PERFORM MAINTENANCE ON VALVES OR FILTERS WITH THE ADSORPTION VESSEL PRESSURIZED.**

1. To reduce start up time, close both manual ball valves (MIV 101 and MIV 102) on NST 101 to keep nitrogen inside. Carefully set aside the pressurized tank until the valve rebuild process is finished. Refer to flow diagram (Figure 4).



Parker Hannifin Corporation
 Gas Separation and Filtration Division
 4087 Walden Ave.
 Lancaster, NY 14086
 www.parker.com

2. Remove side panels and lower front access panel.
3. Depressurize the system by opening MBV 101 & 102 to bleed trapped gas from both sets of vessels (see Figure 17). This can be accomplished by opening the valves slowly. Open manual bleed valves and drain valves found on the filter housings

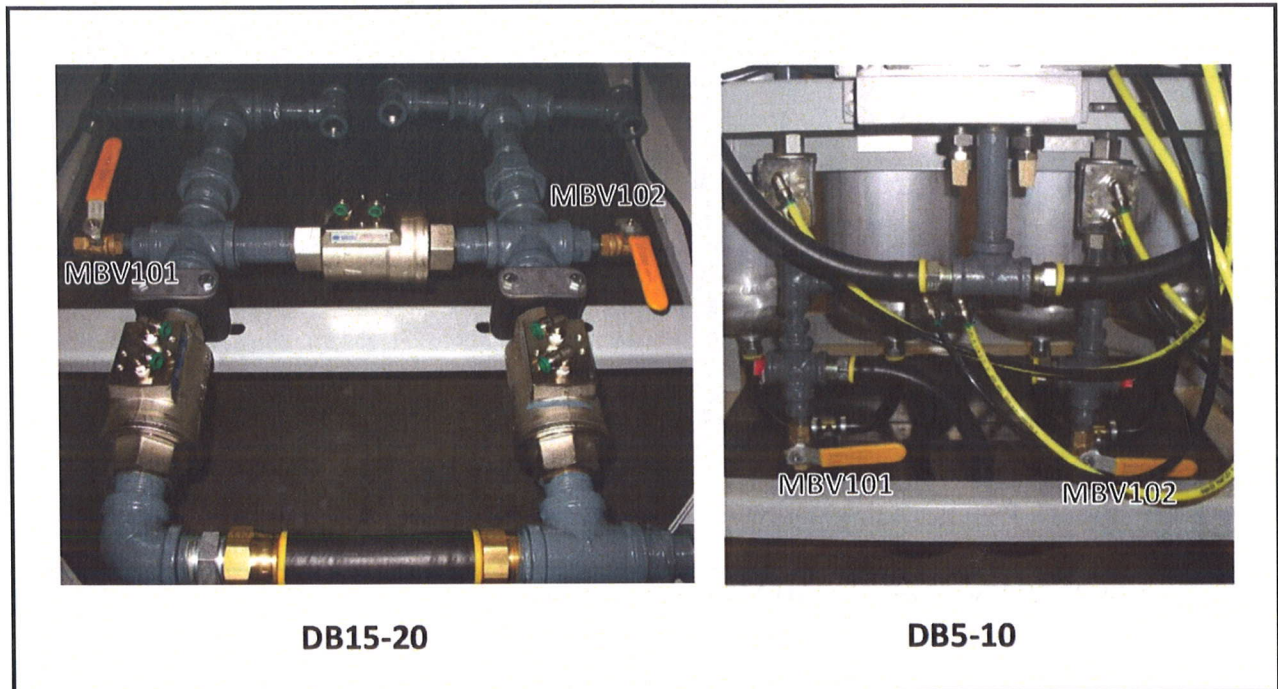

Figure 9: Manual Bleed Valves

- ⚠ CAUTION:** Label hoses, tubing, and fittings before disconnecting to insure proper re-assembly and generator operation after rebuild procedure is complete.
- ⚠ CAUTION:** Excessive oil or moisture levels in the air will cause irreversible contamination of the CMS material in the Adsorption Vessel. Take extra care to prevent exposure of the CMS material to a moist environment during service. If there is any indication or suspicion of excessive oil levels in the feed air (e.g., oil-saturated filter elements, dryer malfunction), find and correct problem(s) before re-installing the nitrogen generator.

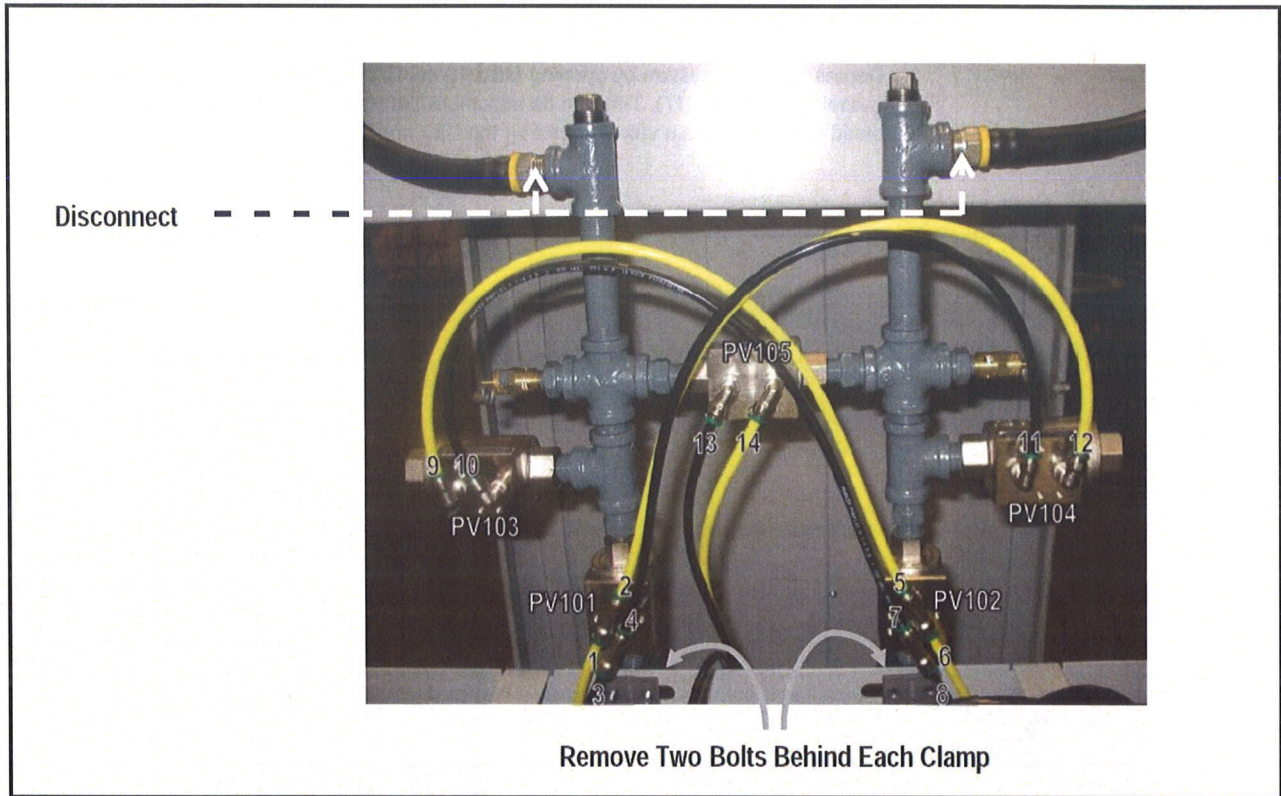

Figure 10: DB-5/10 Top Manifold - Label All Tubing connections

4. Remove top manifold:
 - a. For DB-5/10:
 - i. Disconnect rubber hose fittings at three places:
 - 1) Left side
 - 2) Right side
 - 3) Upstream of top manifold – located underneath PV 102
 - ii. Label all process valve tubing connections - 14 total.
 - iii. Disconnect tubing from elbows and tees - all 14 (Figure 11).
 - iv. Remove clamp hex bolts that secure manifold. Ensure that manifold is supported while removing clamp bolts (Figure 11).
 - b. For DB-15/20:
 - i. Disconnect rubber hose fittings at four places on top manifold (Figure 12):
 - 1) Both fittings at feed process valves PV 101 and PV 102 (dotted line)
 - 2) Both hose fittings at the tees going to both AV101 and AV102 (dotted line).
 - ii. Label all process valve 1/4 in. flexible tubing connections - 14 total.
 - iii. Disconnect tubing from elbows and tees - all 14 (Figure 12).
 - iv. While supporting manifold, remove all four clamp hex bolts that secure manifold to frame (hidden in Figure 12).

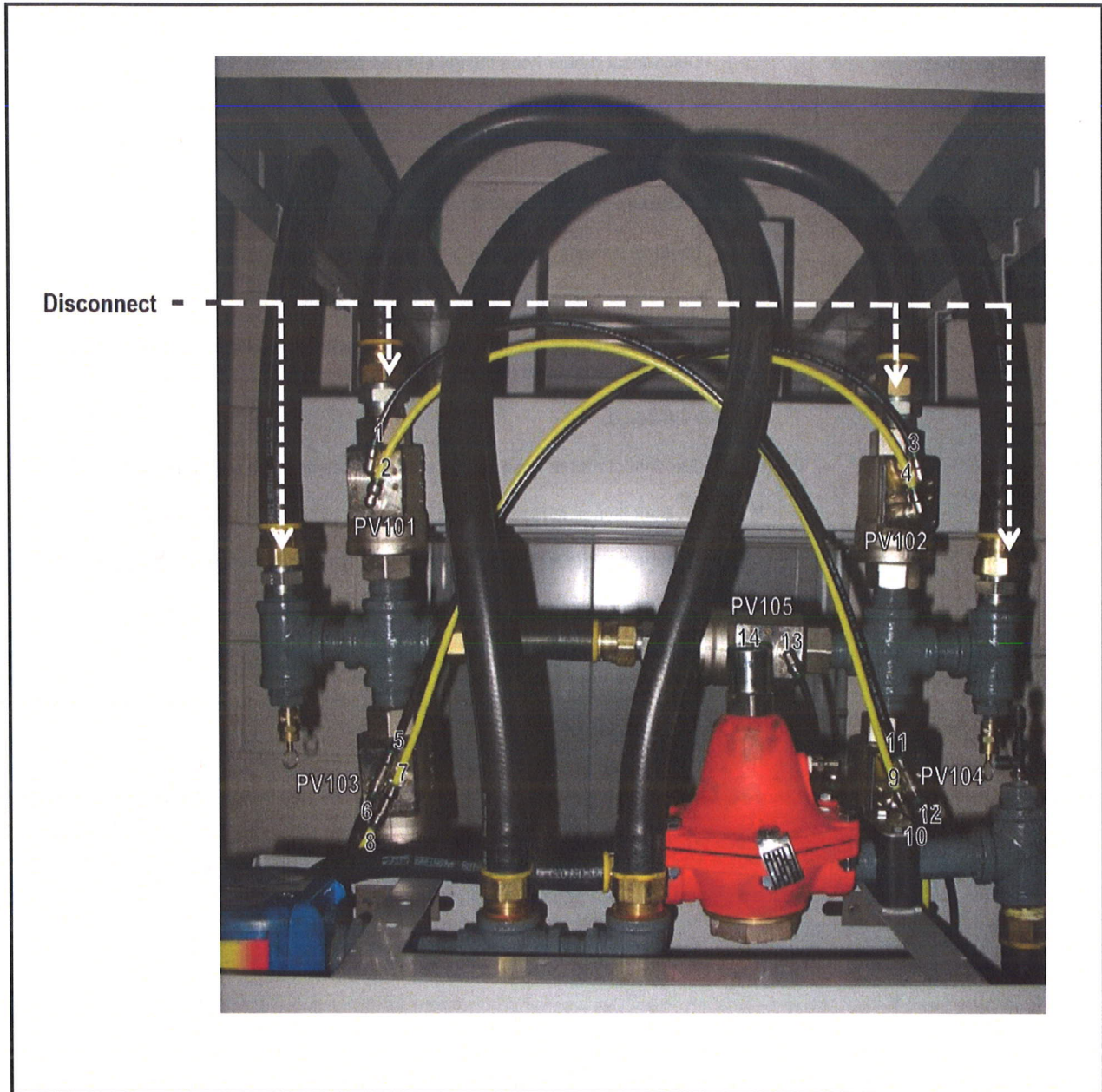

Figure 11: DB-15/20 Top Manifold - Label All Tubing Connections

5. Plug and seal any hose/tubing that leads to the adsorption vessels to avoid moisture contamination of the CMS material.
6. Carefully disassemble manifold to rebuild each process valve:
 - a. Secure each valve body in a vise, then unscrew top to open.
 - b. Disassemble subcomponents, and replace o-rings and seat material as shown in Figure 13.
 - c. Apply white lithium grease to all seals, cups and seats during assembly.

NOTE: Reassembly will be made easier if the piping is left connected to the valve bodies as much as possible during this process. When practical, leave piping, elbows and tees connected when opening the valve bodies.

7. Reassemble manifolds and install in generator in the opposite manner in which they were removed.

NOTE: Clean hose and brass tube fitting threads well, and apply proper layering of PTFE tape and correct amount of pipe paste.

⚠ CAUTION: Ensure that pipe paste does not spill or squeeze into the inner space of the hose and/or fitting.

8. Remove bottom manifold:
 - a. For DB-5/10:
 - i. Disconnect rubber hose fittings at three places (Figure 14):
 - 1) Left side
 - 2) Right side
 - 3) Downstream of manifold – located above PV 108.
 - ii. Label all process valve tubing connections - six total.
 - iii. Disconnect tubing from elbows and tees - all six.
 - iv. While supporting the manifold, remove clamp hex bolts that secure manifold (Figure 14).



Parker Hannifin Corporation
Gas Separation and Filtration Division
4087 Walden Ave.
Lancaster, NY 14086
www.parker.com

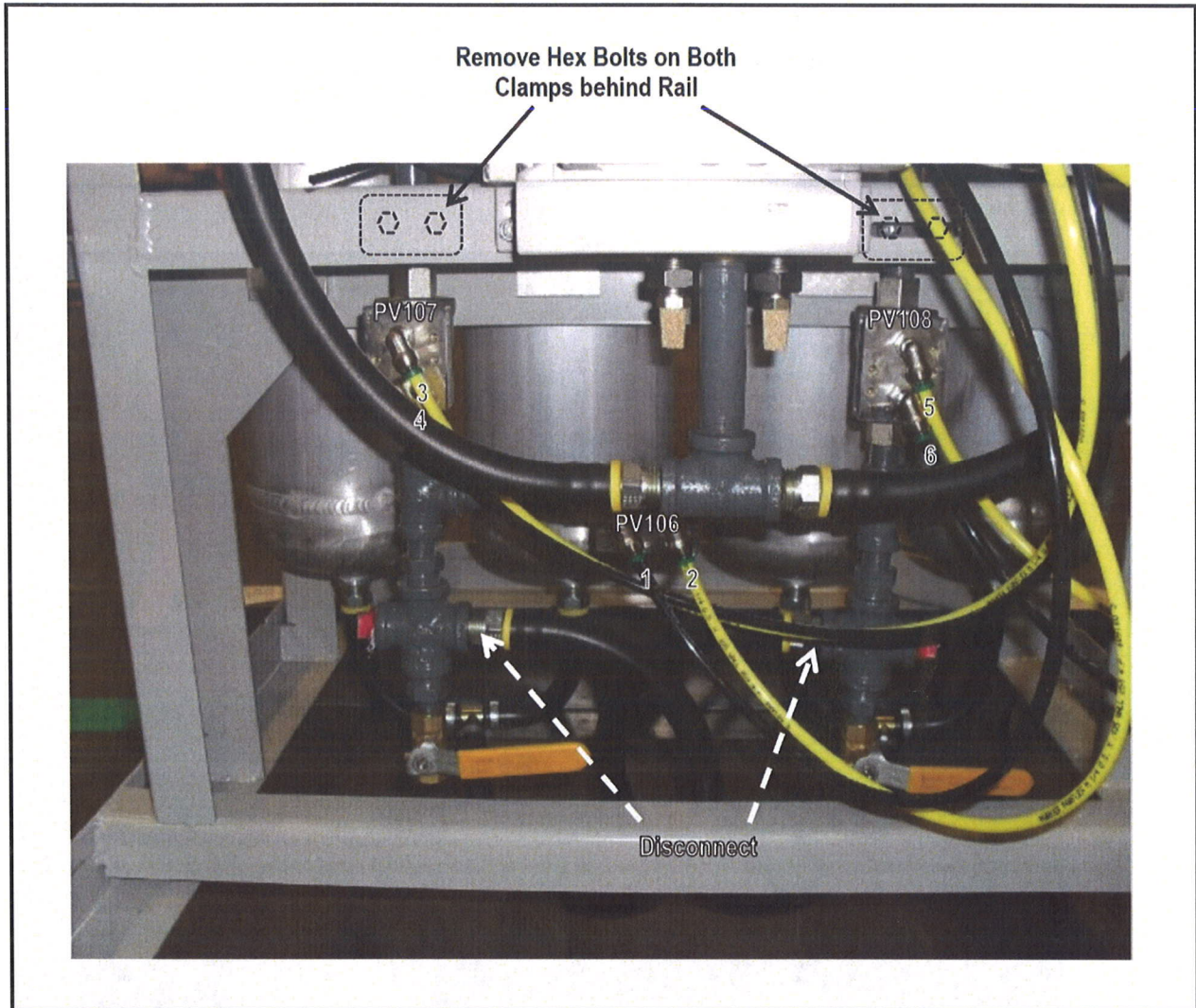

Figure 13: DB-5/10 Lower Manifold - Label All Tubing Connections

- b. For DB-15/20 (Figure 15):
 - i. Disconnect rubber hose fittings at nine places (seven places for DB-15):
 - 1) Manifold tees underneath the vessels - eight disconnections.
 - 2) After-filter tee upstream side.
 - ii. Label all process valve tubing connections - six total.
 - iii. Disconnect tubing from elbows and tees - all six (Figure 15).



Parker Hannifin Corporation
Gas Separation and Filtration Division
4087 Walden Ave.
Lancaster, NY 14086
www.parker.com

- iv. Remove clamp hex bolts that secure manifold (Figure 15).
 - v. Remove manifold.
9. Plug and seal any hose/tubing that leads to the adsorption vessels to avoid moisture contamination of the CMS material.

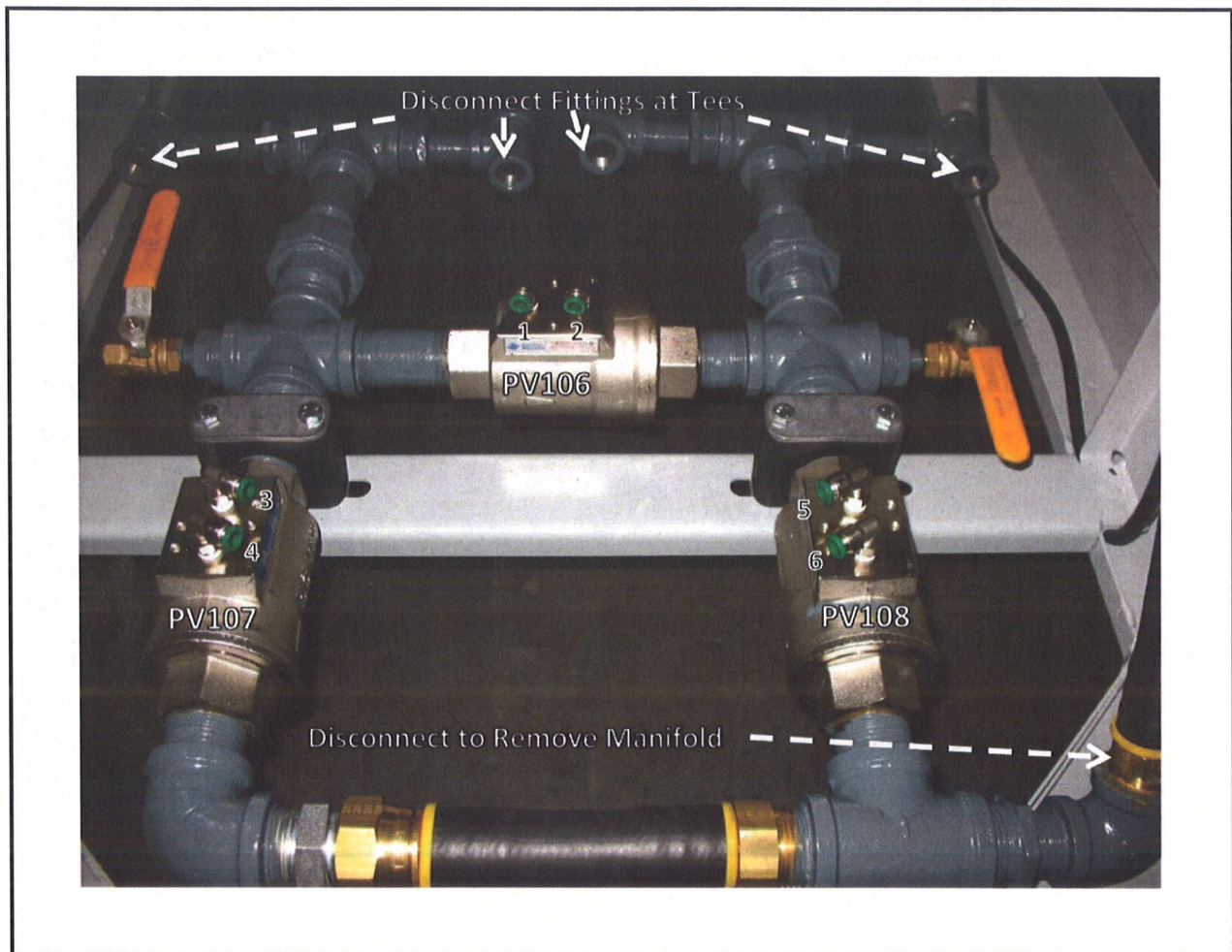

Figure 14: DB-15/20 Bottom Manifold – Tubing Disconnected

10. Carefully disassemble manifold to rebuild each process valve:
- a. Secure each valve body in a vise, then unscrew top to open.
 - b. Disassemble subcomponents, and replace o-rings and seat material as shown in Figure 13.

- c. Apply white lithium grease to all seals, cups and seats during assembly.

NOTE: Reassembly will be made easier if the piping is left connected to the valve bodies as much as possible during this process. When practical, leave piping, elbows and tees connected when opening the valve bodies.

11. Reassemble manifolds and install in generator in the opposite manner in which they were removed.

NOTE: Clean hose and brass tube fitting threads well, and apply proper layering of PTFE tape and correct amount of pipe paste.

 **CAUTION: Ensure that pipe paste does not spill or squeeze into the inner surface of the hose and/or fitting.**

12. Turn on DB unit, and perform bubble soap test to check for leaks.
13. Fix any leaks that are found.
14. Reattach side panels and front access panel.



Parker Hannifin Corporation
Gas Separation and Filtration Division
4087 Walden Ave.
Lancaster, NY 14086
www.parker.com

Pilot Valve Maintenance

Pilot valve spools should be inspected every 1,000 operating hours, and replaced if necessary. Otherwise the spool should be replaced every 2,000 hours. Reference the on-board hour meter (see Figures 3 and 19) for elapsed operation time. Maintenance to the solenoid pilot stack valve consists mainly of replacing the aluminum spool and gaskets. A small pair of needle nose pliers may be needed to grab the spool on the Parker solenoid stack valve. When replacing the spool, make sure that it is installed the same way it came out. Failure to do so will result in valve/system malfunction.

Procedure

NOTE: Make sure that the system is depressurized.

Parker H-Series Pilot Valve

1. Remove lower front access panel, and locate solenoid stack valve below electrical box (Figure 3).
2. Remove four mounting screws on pilot valve body using 4mm hex key (Figure 16) to disengage from stack.

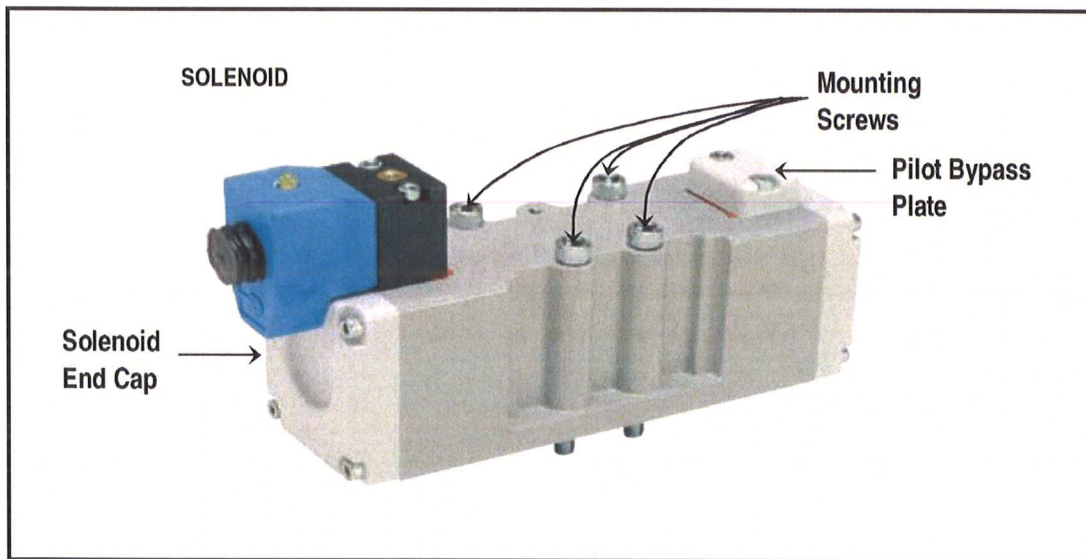

Figure 15: Typical Parker H-Series Pilot Valve

3. To change pilot select gaskets (follow instructions supplied in service kit):

⚠ CAUTION: If the new pilot select gaskets are not oriented properly, the generator will not cycle properly. Take note of old gasket orientation before disassembly. Both tabs should be on the bottom pointing towards center of pilot valve body.

- a. Remove two solenoid screws using 3mm hex key (See Figure 16).
- b. Remove old gasket, taking note of orientation, and replace with new one. Ensure that new gasket is positioned properly. The tab on the gasket should be pointing to the etched "I," towards the bottom (Figure 17).
- c. Replace coil-to-end cap gasket with new part, if supplied in kit.
- d. Remove pilot bypass plate.
- e. Remove old gasket and replace with new one. Ensure that new gasket is oriented properly. The tab on the gasket should be pointing to the etched "I," towards the bottom.
- f. Re-install solenoid pilot operator. Torque screws to 12-14 in.lb (1.4-1.6 Nm).

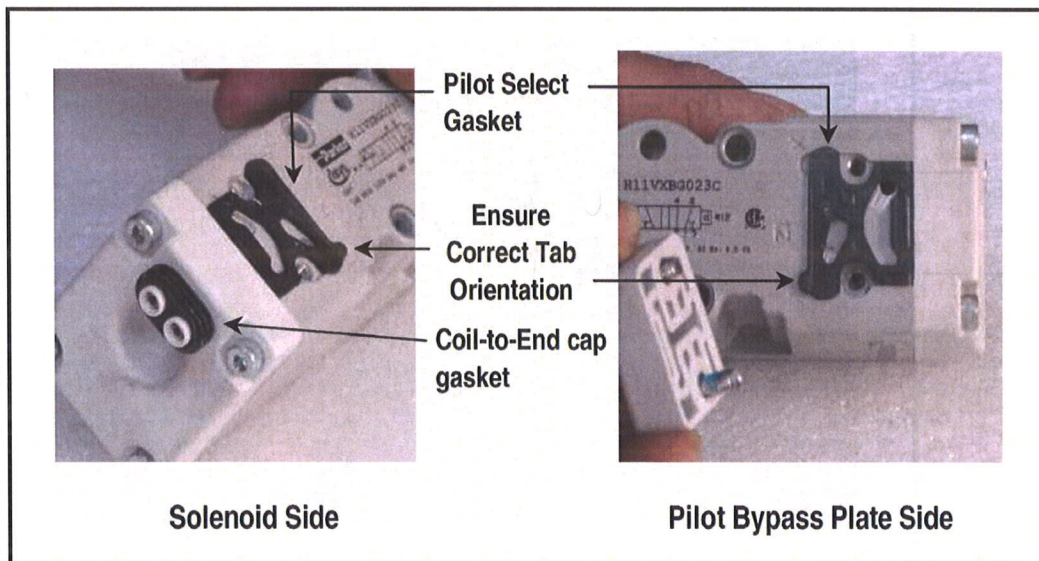

Figure 16: Two Pilot Select Gaskets - Orientation

4. To change valve spool (Figure 18):
 - a. Remove solenoid end cap using 3mm hex key.

 **CAUTION: Note proper piston orientation.**

- b. Remove piston. Refer to instructions supplied in service kit for additional information. Replace piston lip seal with new seal.
- c. Using needle-nose pliers, carefully grab end of spool firmly, and pull out of valve body.
- d. Lightly lubricate new spool with packaged lubricant, and insert spool back into valve body.
- e. Clean piston with clean lint-free cloth, and lightly grease with provided lubricant.
- f. Install piston correctly.
- g. Replace solenoid end cap, and torque screws to 12-14 in.lb (1.4-1.6 Nm). Replace coil-to-end cap gasket.

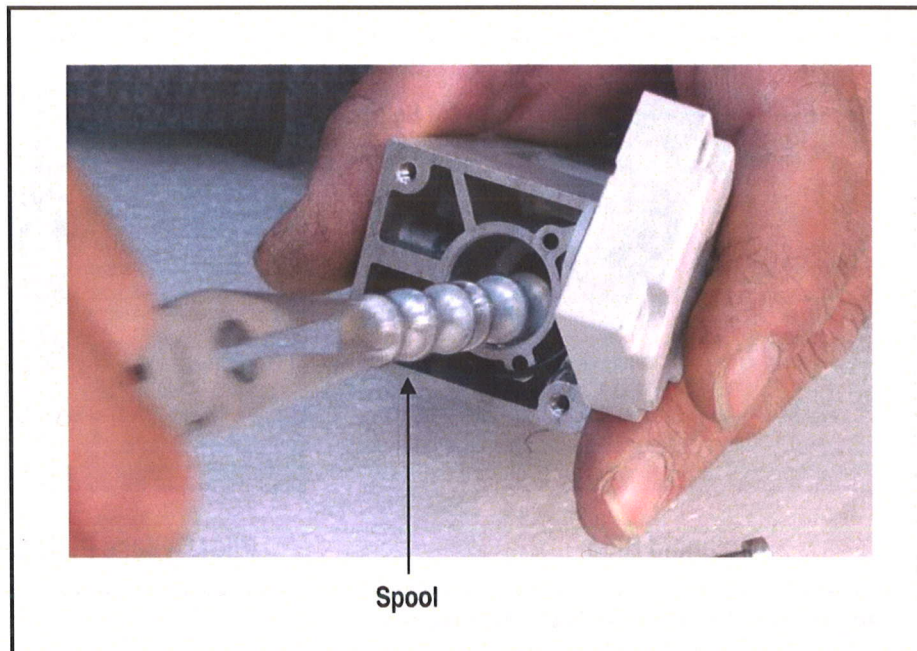

Figure 17: Valve Spool Replacement with Needle-nose Pliers

Spare Parts Ordering Information

Part Description		P/N for DB-5 & 10	P/N for DB-5-EC, DB-10-EC, DB-15 & 20
Filter Elements & Valve Repair Kits	Prefilter (CF 101) – Replacement Element	5/100-18-BX	5/200-35-BX
	Final Filter (AF 101) – Replacement Element (box of 5)	5/100-12-SA	5/200-176-SA (For units with s/n: 6460 and lower use 5/150-19-SA)
	Process Valve Repair Kit (PV 101, 102, 105-108) QTY. 6	RKVA037VV	RKVA100VV
	Process Valve Repair Kit (PV 103, 104) QTY. 2	RKVA050VV	RKVA100VV
	H-Series Solenoid Pilot Valve Repair Kit for (SPV 101-103) QTY. 3	PS4001CP	PS4001CP
Oxygen Monitor Fuel Cells	Parker/Balston 72-730 (Standard Units)	72695	72695
	Advanced Instruments % Oxygen Analyzer	GPR-11-60-4	GPR-11-60-4
	Advanced Instruments Trace Oxygen Analyzer	GPR-12-333	GPR-12-333
Fuses	Balston Analyzer, 0.1 amp, 250 volt - QTY. 2	13221	13221
	Main power, 1.5 amp, 250 volt – QTY. 2	71924526	71924526

Maintenance Kits

Kit Information	P/N for DB-5 & 10	P/N for DB-5-EC, DB-10-EC, DB-15 & 20
Basic Maintenance Kit (no Oxygen Analyzer) <ul style="list-style-type: none"> ➤ CF 101 filter element – qty. 2 ➤ AF 101 filter element – qty. 2 ➤ Pilot valve Repair kit – qty. 3 ➤ Process Valve Repair Kit (sizes of valves vary, depending on the model) – qty. 8 	MKDB5	MKDB15SS1. (For units with s/n: 6460 and lower use: MKDB15)
Basic Maintenance + Analyzer Kit (for units with Balston Analyzer) <ul style="list-style-type: none"> ➤ All components included with the Basic Maintenance Kit ➤ Oxygen Analyzer Fuel Cell P/N 72695 	MKDBO5	MKDBO15SS1 (For units with s/n: 6460 and lower use: MKDBO15)
Basic Maintenance + % Analyzer Kit (for units with Advanced Instruments % Oxygen Analyzer) <ul style="list-style-type: none"> ➤ All components included with the Basic Maintenance Kit ➤ Advanced Instruments % Oxygen Analyzer Fuel Cell P/N GPR-11-60-4 	MKDBOC5	MKDBOC15SS1 (For units with s/n: 6460 and lower use: MKDBOC15)
DB5-20 Basic Maintenance + Trace Analyzer Kit (for units with Advanced Instruments Trace Oxygen Analyzer) <ul style="list-style-type: none"> ➤ All components included with the Basic Maintenance Kit ➤ Advanced Instruments Trace Oxygen Analyzer Fuel Cell P/N GPR-12-333 	MKDBOD5	MKDBOD15SS1 (For units with s/n: 6460 and lower use: MKDBOD15)

For placing orders for replacement parts or repair kits, call 1-800-343-4048.



Parker Hannifin Corporation
Gas Separation and Filtration Division
4087 Walden Ave.
Lancaster, NY 14086
www.parker.com

Additional emergency spare parts

Certain maintenance parts are recommended to be on hand for when they are needed. These include filters, valve rebuild kits and oxygen analyzer fuel cells. Other parts may fail rarely but when they do the machine will be down until that item is replaced. Even if the part is in stock at our plant it can take from 1 to 3 days to get the part and have the machine back up and running. If it is imperative that your generator remain in service, we suggest you also keep the following parts in your stock.

10ea)	Fuse, 1.5 amp	71924526
1ea)	Solenoid valve	H11VXBG023C
2ea)	Solenoid coil	PS404123P
1ea)	PLC, Koyo	D0-05AA
1 ea)	Pressure regulator	R1002D

Refer to Figures 19 (DB-5/10) and 20 (DB-15/20) for diagrams of replaceable parts.

Expansion Kits

DB-5 generators may be converted in the field to DB-10's and DB-15's may be converted to DB-20's using the expansion kit, P/N EXP-DB-01. Please consult the factory for details on this option.

For placing orders for replacement parts or repair kits, call 1-800-343-4048.



Parker Hannifin Corporation
Gas Separation and Filtration Division
4087 Walden Ave.
Lancaster, NY 14086
www.parker.com

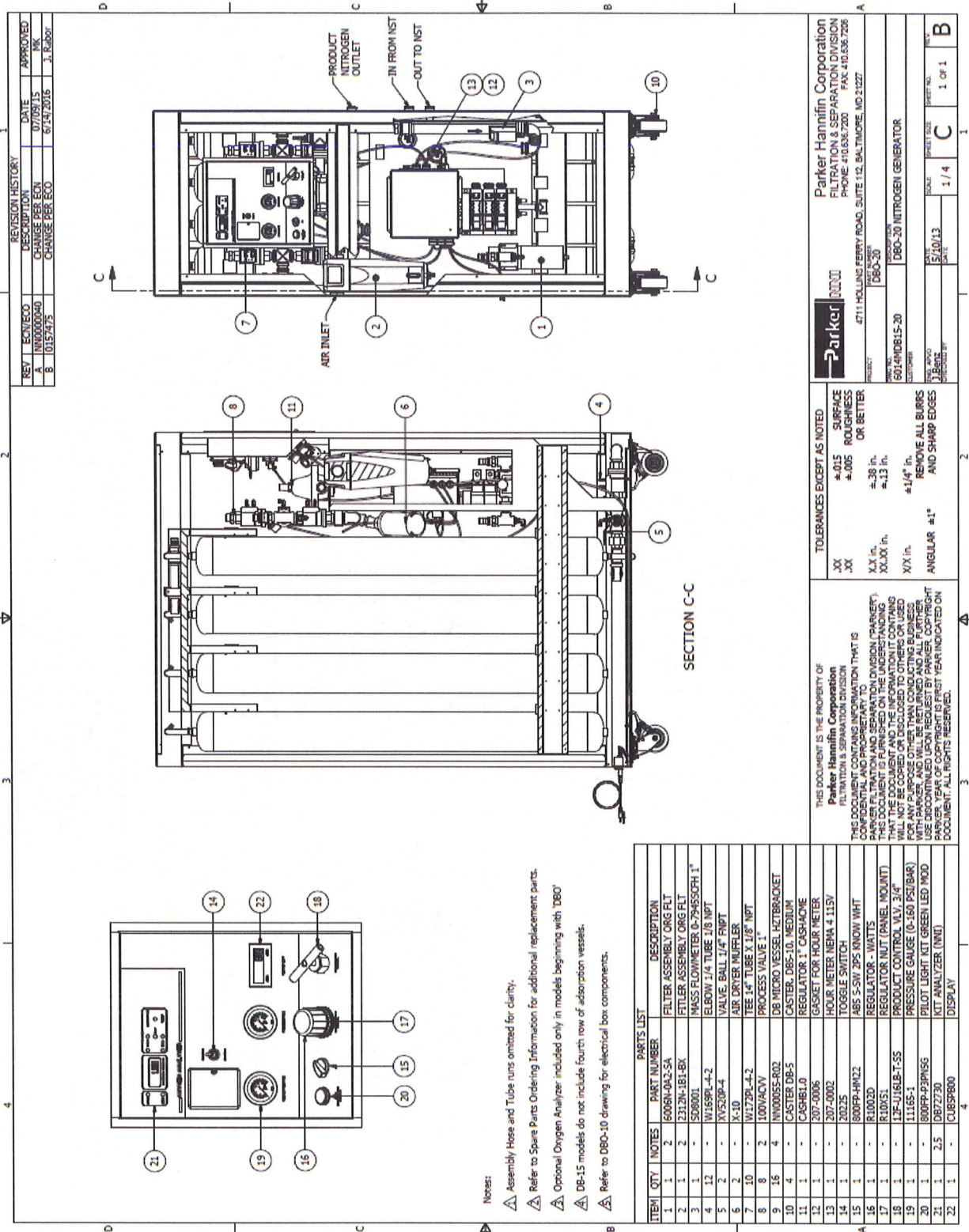



Figure 19: DB-15/20 Replaceable Parts



Parker Hannifin Corporation
 Gas Separation and Filtration Division
 4087 Walden Ave.
 Lancaster, NY 14086
 www.parker.com

Warnings and Precautions

- Oil Contamination** Excessive oil levels in the inlet air are very detrimental to the Adsorption Vessel Carbon Molecular Sieve (CMS) material. Irreversible contamination of the CMS material is possible if oil levels are too high. If there is any indication or suspicion of excessive oil levels in the feed air (e.g., oil-saturated filter elements, dryer malfunction, loss of Dual-Bed performance), shut unit down, find and correct problem(s) before restarting. If the Dual-Bed unit is allowed to run with high oil content in the feed air, a major loss in performance is possible, necessitating a partial or complete CMS bed replacement.
- Moisture Contamination** High moisture (water) content in the inlet air may be detrimental to the Dual-Bed unit's performance. While not as serious as oil contamination, a loss in performance will result. If a dryer, coalescing filter, or automatic drain malfunction is observed or suspected, shut unit down and correct problem(s) before re-starting.
- Carbon Dust** A small amount of intermittent CMS (carbon) dust on the inside of final filter element does not present a problem. However, if accumulations of powder on filter element, or exhausting from the silencer during blow-down are observed, shut unit down **IMMEDIATELY** and contact factory. Excessive dust indicates physical deterioration of the CMS material, and will require replacement of carbon vessels.
- Initial Start Up** Before initial start up, check all filters to verify filter elements are secured in place. Elements tend to shake loose during transit. Serious loss in performance and carbon contamination may result if filter elements are loose and or if the o-ring gasket is not making a seal with the filter head assembly. Correct any problems before proceeding with startup.
- Adequate Ventilation** As Nitrogen is inert and can displace breathing air, it is imperative to avoid leaking or exhausting the gaseous product Nitrogen into a confined area where plant personnel may be present. Adequate ventilation should always be maintained in the area where the Nitrogen Generator is to be operated.

 **CAUTION:** Before performing any maintenance on the system such as repairing valves or changing filter elements, make sure system is fully depressurized and isolated from the air system. Failure to do so can cause serious injury.



Parker Hannifin Corporation
Gas Separation and Filtration Division
4087 Walden Ave.
Lancaster, NY 14086
www.parker.com

Troubleshooting and Service



All troubleshooting and service activities should be performed by suitable personnel using reasonable care.

Symptom – Nitrogen Generator	Course of Action
No Power to Machine	Check for blown fuses (see p.17)
Loss of Outlet Pressure	Check that the flow control valve on the generator is adjusted properly. Check inlet pressure to assure that it is greater than 110 psig. Check the system for leaks.
Loss of Outlet Flow	Check inlet pressure to assure that it is greater than 110 psig. Check setting of flow control valve. Adjust if necessary. Check the system for leaks. Check power. Check that PLC 'Run' switch is in the "On" position.
Purity is Lower than Specified for Operating Conditions	Check the inlet air pressure to assure that it has not varied from the original reading. Check the system for leaks, including the drain petcock on the NST. Measure the temperature and dewpoint of the inlet air. The recommended temperature is 77°F (25°C) and the recommended dewpoint is 40°F (4°C) or lower. Calibrate Oxygen analyzer (if needed). Check inlet pressure to assure that it is greater than 110 psig.
Air Leak Through Drain of Prefilter	Check inlet pressure. It should be greater than 15 psig to seal drain. Hold finger over drain opening for a few seconds to allow pressure to build and drain to seal. Remove bowl from filter assembly and rinse with water. If leak persists, replace automatic float drain.
Symptom – Oxygen Analyzer	Course of Action
No Power to Analyzer	Check for blown fuses (see p.18)
Display Varies	Check process flow demand. Check sample lines for leaks. Recalibrate oxygen analyzer.
Limited range during calibration	Replace oxygen sensor.

To arrange for system service, contact the Technical Services Department at 410-636-7200, 8AM to 5PM Eastern Time or email at balstontechsupport@parker.com (North America only). For other locations please contact your local representative.

Serial Numbers

A four digit serial number can be found on the front of the DB nitrogen generator. For your own records, and in case service is required, please record the following:



Parker Hannifin Corporation
 Gas Separation and Filtration Division
 4087 Walden Ave.
 Lancaster, NY 14086
www.parker.com

DATE IN SERVICE _____ SERIAL NO. _____

PRODUCT WARRANTY – INDUSTRIAL NITROGEN GENERATORS (standard product)

1. Subject to the terms and conditions hereof, Parker Hannifin Corporation (PARKER) guarantees to the original purchaser of any Parker product (PRODUCT) installed and used as recommended by PARKER in normal service, that if the PRODUCT fails or is materially defective within 12 months from the date of installation or 18 months from date of shipment, of such PRODUCT, then PARKER, at PARKER'S sole option, will replace the PRODUCT with the same or equivalent PRODUCT, repair the PRODUCT, or refund the original purchase price for the PRODUCT. Such replacement, repair or payment by PARKER shall be in complete satisfaction of any and all liability of PARKER and its agents with respect to such PRODUCT. The aforementioned PRODUCT warranty covers replacement parts and depot repair at our factory in Haverhill, MA only and does NOT cover on-site labor.

2. Industrial Nitrogen Generators that are installed with a Parker Nitrogen Generator with a Parker air dryer (refrigerated or desiccant) or another dryer system that supplies compressed air to ISO 8573-1 3.2.2 will receive an additional 12 months warranty. Therefore the total warranty due to defects in materials or workmanship will be for 24 months from installation or 30 months from date of shipment, whichever is shorter.

3. This warranty shall be void in case of:

- a. Any buyer's modifications not explicitly approved by Parker Filtration and Separation.
- b. Misuse or failure in maintenance - not in accordance with Parker's product recommendations
- c. Use of unauthorized or non-genuine Parker replacement parts.
- d. Contamination of the product with particles, solvents, oils, water, rust, etc., due to inadequate pre-filtration.

4. THE FOREGOING IS THE ONLY WARRANTY, GUARANTEE OR REPRESENTATION OF ANY KIND MADE WITH RESPECT TO ANY PARKER PRODUCT. NO IMPLIED WARRANTY, INCLUDING ANY IMPLIED WARRANTY OF MERCHANTABILITY OR FITNESS FOR A PARTICULAR PURPOSE, APPLIES TO THE PRODUCT AFTER THE WARRANTY PERIOD STATED ABOVE, AND NO OTHER EXPRESS WARRANTY OR GUARANTEE, EXCEPT AS MENTIONED ABOVE, GIVEN BY ANY PERSON, FIRM OR CORPORATION WITH RESPECT TO THE PRODUCT SHALL BIND PARKER. PARKER SHALL NOT BE LIABLE FOR LOSS OF REVENUES OR PROFITS, EXPENSE FOR SUBSTITUTE EQUIPMENT OR SERVICE, STORAGE CHARGES, OR ANY OTHER SPECIAL, INCIDENTAL OR CONSEQUENTIAL DAMAGES CAUSED BY THE USE, MISUSE OR INABILITY TO USE THE PRODUCT REGARDLESS OF THE LEGAL THEORY ON WHICH THE CLAIM IS BASED, AND EVEN IF PARKER HAS BEEN ADVISED OF THE POSSIBILITY OF SUCH DAMAGES. NOR SHALL RECOVERY OF ANY KIND AGAINST PARKER BE GREATER IN AMOUNT THAN THE PURCHASE PRICE OF THE PRODUCT SOLD BY PARKER AND CAUSING THE ALLEGED DAMAGE. WITHOUT LIMITING THE FOREGOING, YOU ASSUME ALL RISK AND LIABILITY FOR LOSS, DAMAGE OR INJURY TO YOU AND YOUR PROPERTY AND TO OTHERS AND THEIR PROPERTY ARISING OUT OF USE, MISUSE OR INABILITY TO USE THE PRODUCT NOT CAUSED DIRECTLY BY THE NEGLIGENCE OF PARKER. THIS LIMITED WARRANTY IS GIVEN ONLY WITH RESPECT TO A PRODUCT PURCHASED FROM PARKER OR AN AUTHORIZED PARKER DISTRIBUTOR.

5. This guarantee does not extend to any PRODUCT defect or failure which occurs more than one (1) year after the original purchase date, or to any PRODUCT with a normal useful life of less than one (1) year (such as, but not limited to, PARKER filter cartridges, or routine maintenance items as recommended by the PRODUCT'S instructions) or to any PRODUCT which is or becomes defective as a result of (a) any failure by any party other than PARKER to handle, ship, use, store or maintain the PRODUCT other than in accordance with PARKER'S directions or instructions and/or generally accepted trade or industry practices or (b) any event or circumstance which is not reasonably within the full and exclusive control of PARKER or its agents or employees.

6. Defective PRODUCTS must be documented via PARKER FNS "Claim Number" within thirty (30) days after the date of the alleged failure or defect by contacting Parker Technical Support via email at gsfsupport@parker.com or via phone at 800-343-4048, option 2. The claim must specify in reasonable detail: 1) Product Serial Number or Parker Sales Order # and approximate Date of Purchase; 2) Where or from whom the product was originally purchased; 3) Description of problem symptom; 4) Description of troubleshooting effort details; 5) Description of physical location and/or environment details.

7. PARKER shall have the right to require the failed or defective PRODUCT to be shipped to PARKER at PARKER'S expense and/or to inspect the failed or defective PRODUCT in its operative environment. The purchaser shall cooperate with PARKER in its investigation and provide full information and documentation concerning the PRODUCT and its usage. This guarantee shall be construed and enforced under the laws of the Commonwealth of Massachusetts.



Parker Hannifin Corporation
Gas Separation and Filtration Division
4087 Walden Ave.
Lancaster, NY 14086
www.parker.com

Principal Specifications**Nominal Conditions – DB-5 thru DB-20**

Feed Pressure:	110 psig
Temperature:	77°F (25°C)
Ambient Pressure:	14.7 psig (1 Atmosphere)

Compressed Air Specifications – DB-5 thru DB-20

Max. Pressure:	140 psig
Temperature Range:	60°F - 105°F (16°C - 40°C)
Dewpoint:	40°F (4°C) pressure dewpoint or better
Residual Oil Content:	Trace
Particles:	<.01μ



Parker Hannifin Corporation
Gas Separation and Filtration Division
4087 Walden Ave.
Lancaster, NY 14086
www.parker.com

Ambient Conditions – DB-5 thru DB-20

Temperature Range:	40°F - 95°F (4°C - 35°C)
Ambient Pressure:	Atmospheric
Air Quality:	Clean Air w/o Contaminants

Dimensions, Weights, and Connections

	DB-5	DB-10	DB-15	DB-20
Dimensions	28.50"L x 32.25"D x 77.75"H	28.50"L x 32.25"D x 77.75"H	28.50"L x 51.50"D x 77.75"H	28.50"L x 51.50"D x 77.75"H
Weight (w/ N₂ tank)	1065 lbs	1265 lbs	1,553 lbs	1,753 lbs
Inlet	½" NPT	½" NPT	1" NPT	1" NPT
Outlet	½" NPT	½" NPT	¾" NPT	¾" NPT

Outlet Pressure (based on nominal conditions and 60 gal N₂ tank)

DB-5, DB-10, DB-15, DB-20 (99.999 – 98%)	80 psig
DB-20 (97 – 95%)	70 psig



Parker Hannifin Corporation
 Gas Separation and Filtration Division
 4087 Walden Ave.
 Lancaster, NY 14086
 www.parker.com

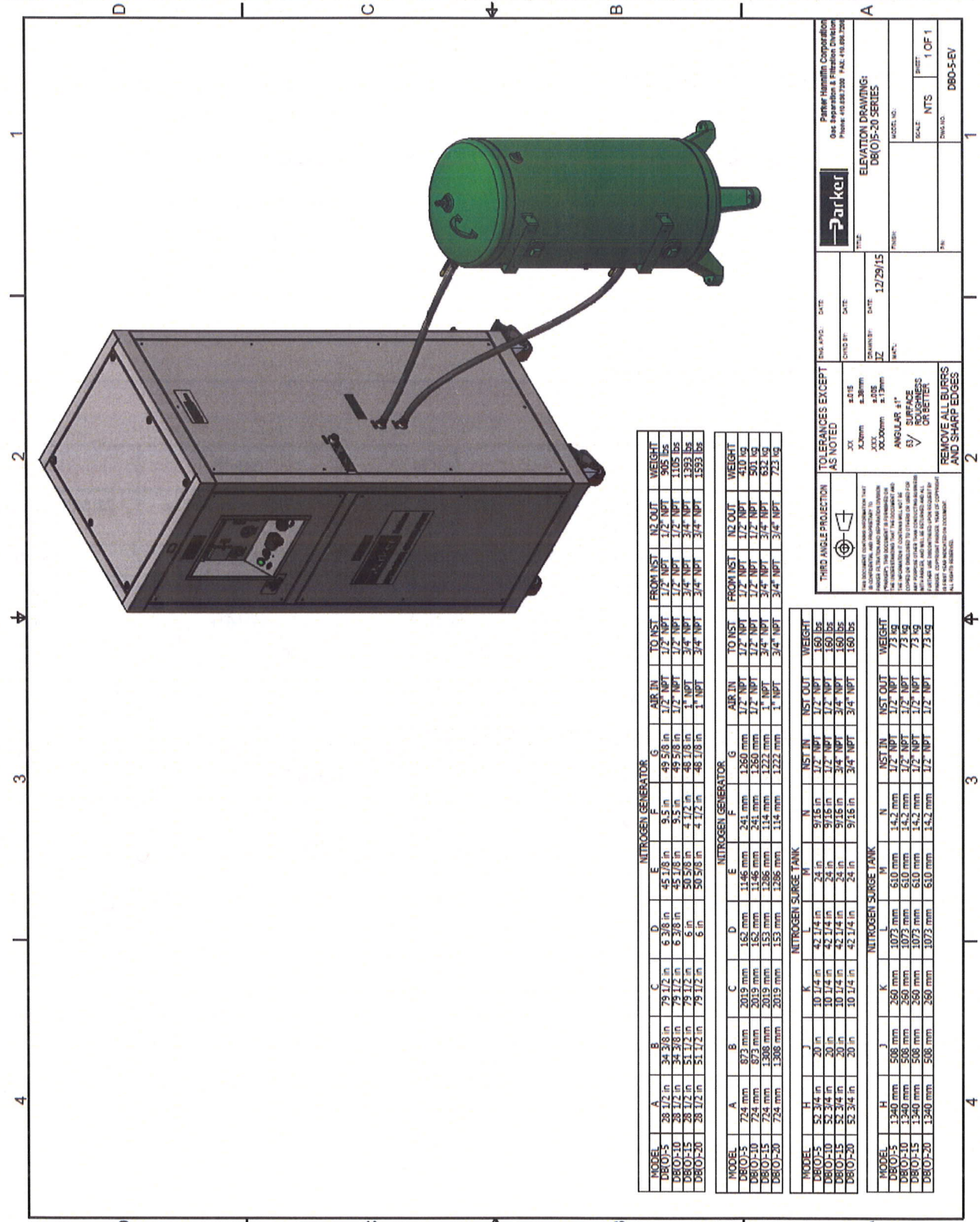

MODEL	NITROGEN GENERATOR				NITROGEN SURGE TANK			
	A	B	C	D	E	F	G	H
DB(O)-5	28 1/2 in	34 3/8 in	79 1/2 in	6 3/8 in	45 1/8 in	9.5 in	49 5/8 in	1.2 in
DB(O)-10	28 1/2 in	34 3/8 in	79 1/2 in	6 3/8 in	45 1/8 in	9.5 in	49 5/8 in	1.2 in
DB(O)-15	28 1/2 in	51 1/2 in	79 1/2 in	6 in	50 5/8 in	4 1/2 in	48 1/8 in	1 in
DB(O)-20	28 1/2 in	51 1/2 in	79 1/2 in	6 in	50 5/8 in	4 1/2 in	48 1/8 in	1 in

MODEL	NITROGEN GENERATOR				NITROGEN SURGE TANK			
	A	B	C	D	E	F	G	H
DB(O)-5	724 mm	872 mm	2012 mm	165 mm	1146 mm	241 mm	1250 mm	30 mm
DB(O)-10	724 mm	872 mm	2012 mm	165 mm	1146 mm	241 mm	1250 mm	30 mm
DB(O)-15	724 mm	1308 mm	2012 mm	152 mm	1286 mm	114 mm	1222 mm	25 mm
DB(O)-20	724 mm	1308 mm	2012 mm	152 mm	1286 mm	114 mm	1222 mm	25 mm

MODEL	NITROGEN GENERATOR				NITROGEN SURGE TANK			
	A	B	C	D	E	F	G	H
DB(O)-5	25 3/4 in	30 in	10 1/4 in	42 1/4 in	34 in	9 1/8 in	42 1/4 in	34 in
DB(O)-10	25 3/4 in	30 in	10 1/4 in	42 1/4 in	34 in	9 1/8 in	42 1/4 in	34 in
DB(O)-15	25 3/4 in	30 in	10 1/4 in	42 1/4 in	34 in	9 1/8 in	42 1/4 in	34 in
DB(O)-20	25 3/4 in	30 in	10 1/4 in	42 1/4 in	34 in	9 1/8 in	42 1/4 in	34 in

MODEL	NITROGEN GENERATOR				NITROGEN SURGE TANK			
	A	B	C	D	E	F	G	H
DB(O)-5	1340 mm	508 mm	360 mm	1073 mm	610 mm	142 mm	1073 mm	160 mm
DB(O)-10	1340 mm	508 mm	360 mm	1073 mm	610 mm	142 mm	1073 mm	160 mm
DB(O)-15	1340 mm	508 mm	360 mm	1073 mm	610 mm	142 mm	1073 mm	160 mm
DB(O)-20	1340 mm	508 mm	360 mm	1073 mm	610 mm	142 mm	1073 mm	160 mm

Parker
 One Separation & Filtration Division
 Phone: 610-281-7200 FAX: 610-281-7201

DATE: 12/29/15
 DRAWN BY: JZ
 CHECKED BY: JZ
 DATE: 12/29/15

SIZE: DB(O)S-20 SERIES
 FINISH: ANGLE 4°
 SURFACE: ES/3
 DIMENSIONS: REMOVE ALL BURRS AND SHARP EDGES

SCALE: NTS
 SHEET: 1 OF 1
 DWG. NO.: DBO-S-EV



Parker Hannifin Corporation
 Gas Separation and Filtration Division
 4087 Walden Ave.
 Lancaster, NY 14086
 www.parker.com

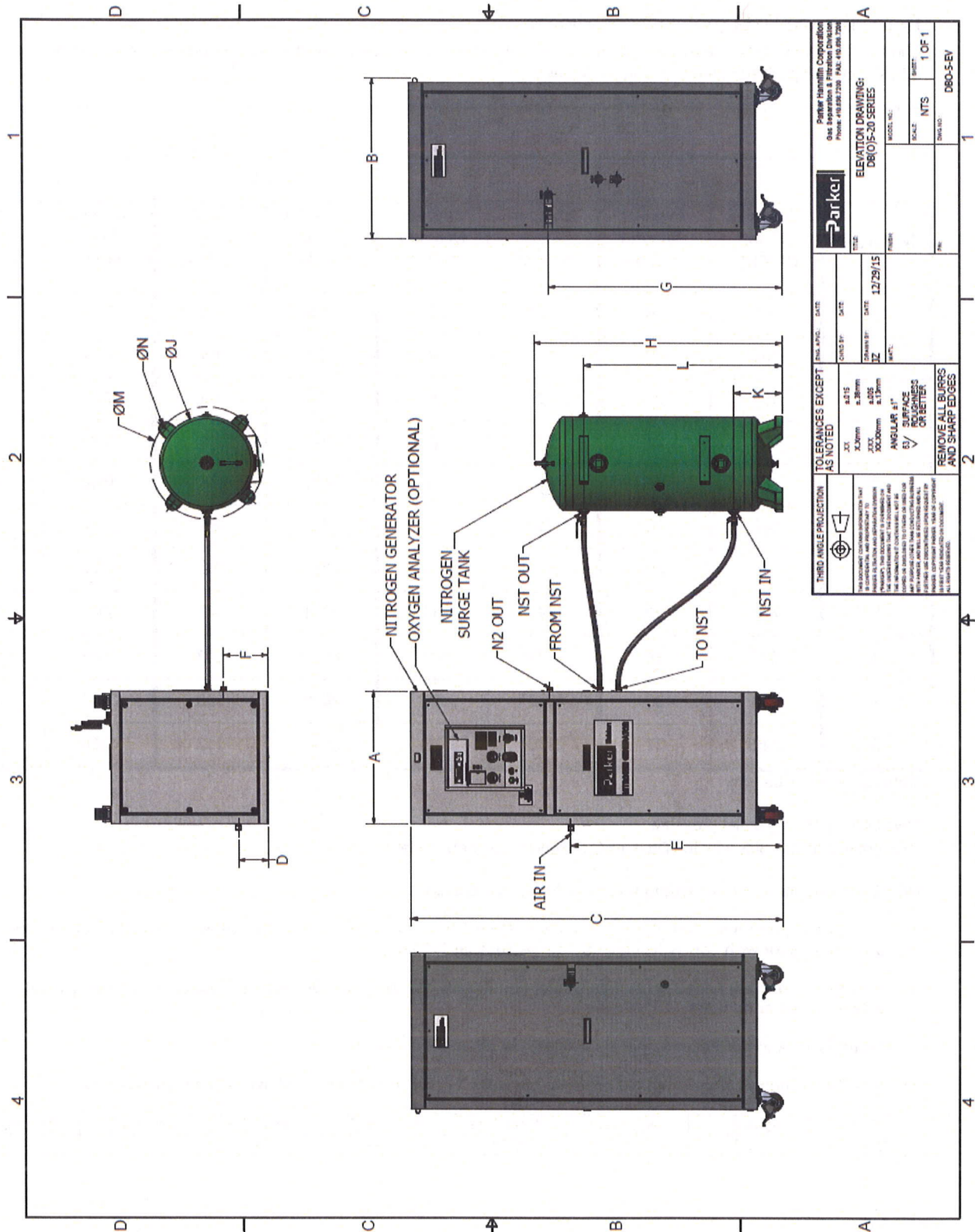

Parker Hannifin Corporation
 Gas Separation and Filtration Division
 4087 Walden Ave.
 Lancaster, NY 14086
 www.parker.com

Performance Data (nominal conditions)

The nitrogen flows below are based on a minimum inlet pressure of 110 psig. Maximum outlet pressure of the nitrogen output is 80 psig unless specified otherwise. See table below.

% Oxygen	DB-5		DB-10		DB-15		DB-20	
	Nitrogen Flow (SCFH) [†]	Avg. Air Demand (SCFM)	Nitrogen Flow (SCFH) [†]	Avg. Air Demand (SCFM)	Nitrogen Flow (SCFH) [†]	Avg. Air Demand (SCFM)	Nitrogen Flow (SCFH) [†]	Avg. Air Demand (SCFM)
.001	94	20	189	41	283	61	377	81
.005	150	21	300	42	450	64	600	85
.01	194	22	388	44	583	66	777	88
.05	314	25	629	49	943	74	1258	98
.1	365	26	730	52	1095	78	1460	105
.5	512	28	1024	57	1536	85	2048	114
1	618	30	1235 ¹	59	1853	89	2470	119
2	770	32	1541 ²	63	2311	95	3081	126
3	892	34	1783 ²	68	2675	103	3566	137
4	983	36	1966 ²	72	2949	108	3931	144
5	1065	37	2130 ²	75	3195	112	4260	149

[†]Nitrogen flow will be ±5%

¹Available at 65 psig outlet pressure.

²Flow rate available only with the DB-10-EC (extended cabinet) model.

NOTE: See items below regarding specified flows and purities.

1. Air Consumption numbers given are average. Peak flows may be considerably higher. Values based on dedicated air compressor with corresponding Air Surge Tank @ 110 psig.
2. Nitrogen values are based on standard inlet conditions (110 psig, 60-100 deg. F). Consult factory for performance at different inlet conditions.
3. Some flows and purities may not be available at all outlet pressures.



Pressure Correction Factors (nominal nitrogen capacity X correction factor = adjusted nitrogen capacity)

70 PSIG	80 PSIG	90 PSIG	100 PSIG	110 PSIG	120 PSIG	130 PSIG	140 PSIG
0.55	0.66	0.77	0.88	1.00	1.08	1.13	1.20



Parker Hannifin Corporation
Gas Separation and Filtration Division
4087 Walden Ave.
Lancaster, NY 14086
www.parker.com

WARNING SYMBOLS

<u>Symbol</u>	<u>Description</u>
	Caution, refer to accompanying documents for explanation.
	Refer to the caution/warning note indicated for explanation.
	Caution, risk of electric shock.

Maintenance Log

Maintenance Performed	Date	Hour Meter Reading	Comments	Initials
Commissioning				

Refer to Filter and Pilot Valve Maintenance sections of this manual for recommended replacement frequency.



Parker Hannifin Corporation
 Filtration and Separations Division
 4711 Hollins Ferry Road, Suite 112
 Baltimore, MD 21227
 www.parker-nni.com

Notes



Parker Hannifin Corporation
Filtration and Separations Division
4711 Hollins Ferry Road, Suite 112
Baltimore, MD 21227
www.parker-nni.com

Notes





Bulletin TI-DB5-20 Rev. K
©Parker Hannifin Corporation, 2015
Printed in U.S.A.



Parker Hannifin Corporation
Gas Separation and Filtration Division
4087 Walden Ave.
Lancaster, NY 14086
www.parker.com